



Installation and Maintenance Manual

CTC EcoAir 700M

Model 708M / 712M

Modulating air-to-water heat pump



Translation of the original instructions.

Keep for future use.

Read carefully before use.

162 605 38-3 CR00950 2024-12-09



MADE IN SWEDEN

Table of contents

1. The complete system	3	11. Installation	27
2. Checklist	4	11.1 Included in the delivery	27
3. Important to remember!	5	11.2 Placement of the heat pump.....	27
3.1 Transportation	5	11.3 Preparation and drainage	28
3.2 Positioning.....	5	11.4 Condensation water	28
3.3 Recycling	6	12. Pipe installation	29
3.4 After commissioning	6	12.1 Pipe connection.....	29
4. Safety Regulations — Flammable refrigerants, safety group A3	7	12.2 Example of connection of the heat pump to CTC EcoZenith (L) indoor module.....	30
5. Connection alternatives	16	12.3 Pressure drop chart.....	31
6. Technical data	17	13. Electrical installation	32
6.1 Electrical data.....	19	13.1 Communication connection	33
7. Dimensional drawing	20	13.2 Connection table for electrical components.....	37
8. Component placement	21	13.3 Wiring diagram 400V 3N~	38
8.1 Refrigerant system.....	24	13.4 Wiring diagram 230V 1N~	42
9. Operating range	25	14. First start	46
9.1 Operating range, heating.....	25	15. Operation and maintenance	46
9.2 Operating range, cooling	25	16. Troubleshooting	49
10. Compressor speed limitation, heating	26		
10.1 EcoAir 708M	26		
10.2 EcoAir 712M	26		

Software update



software.ctc.se

EN

For more information on updated functions and downloading the latest software, see the website "software.ctc.se".

1. The complete system



CTC EcoAir 700M

CTC EcoAir 700M (models 708M, 712M and 720M) is a modulating air-to-water heat pump that transfers heat from the outside air to the property's existing heating circuit. The heat pump works with outside air temperatures as low as $-25\text{ }^{\circ}\text{C}$.

CTC EcoAir 700M can also deliver cooling* together with the control products CTC EcoPart i600M, CTC EcoLogic L/M and CTC EcoZenith i360/CTC EcoVent i360F. The cooling function creates a comfortable indoor climate even on hot days of the year.

Control

CTC EcoAir 700M is controlled by these products:

- CTC EcoLogic L/M*
- CTC EcoLogic S
- CTC EcoPart i600M*
- CTC EcoVent i360F*
- CTC EcoZenith i360*
- CTC EcoZenith i555 Pro

Charge pumps

CTC's PWM-controlled charge pumps are included with the products CTC EcoZenith i360, CTC EcoPart i600M and CTC EcoVent i360F, and are available as accessories for CTC EcoZenith i555 Pro and CTC EcoLogic L/M/S.

Energy labels can be downloaded from www.ctc-heating.com/ecodesign.



Information in this type of box [!] is particularly important for correctly installing and using the product.



Information in this type of box [i] is intended to help ensure that the product functions optimally.

2. Checklist

The checklist must always be completed by the installer

- If a service is performed, you may be required to provide this document.
- Installation must always be carried out according to instructions in the Installation and Maintenance Manual.
- Installation must always be carried out in a professional manner.

Following installation, the unit must be inspected and functional checks performed as indicated below:

Pipe installation (see also the chapter "Pipe installation")

- The heat pump is positioned and adjusted in the correct manner according to the instructions.
- The heat pump is positioned so that it can be serviced.
- Capacity of the charge/radiator pump (depending on type of system) for the flow required.
- Make sure there is flow.
- Open the radiator valves (depending on type of system) and other relevant valves.
- Leak tightness test.
- Bleed the system.
- The safety valves' stated opening pressure. The outdoor unit must have a lower opening pressure than the indoor unit. See the chapter "Pipe installation/Pipe connection" for more information.
- Action taken to deal with condensation water.

Electrical installation (see also the chapter "Electrical installation")

- Operating power switch.
- Correct wiring.
- Requisite sensors fitted.
- Heat pump activated and started.
- Accessories.

Customer information (adapted to the relevant installation)

- Inform that the heat pump contains a flammable refrigerant and the safety risks this involves. Also inform about the heat pump's safety area.
- Startup with customer/installer.
- Menus/controls for selected system.
- Installation and Maintenance Manual supplied to the customer.
- Check and filling, heating circuit.
- Information on fine adjustments.
- Alarm information.
- Function test of the heat pump's safety valve, see section "Periodic maintenance" in chapter "Operation and maintenance".
- Review warranty terms and conditions with the customer.
- Register the product for warranty and insurance via the website 'www.ctc-heating.com'.
- Information on procedures for fault registration.

Date/Customer

Date/Installer

3. Important to remember!

In particular, check the following sections at delivery and installation.

3.1 Transportation

- The heat pump contains the flammable refrigerant R290 with UN number 1978 (hazard identification number 23). Special regulations apply for transportation, loading and unloading of equipment containing this refrigerant.
- The heat pump must be transported and stored upright.

3.2 Positioning

- Transport the heat pump with the packaging to the installation site by crane truck or hand truck if the foundation permits this.
- Remove the packaging and lift the heat pump from the pallet to its final position with the aid of lifting straps that are drawn through the leg frames on both sides.
Remember the following when lifting using a lifting strap:
Lifting heavy weights may cause back and other injuries!

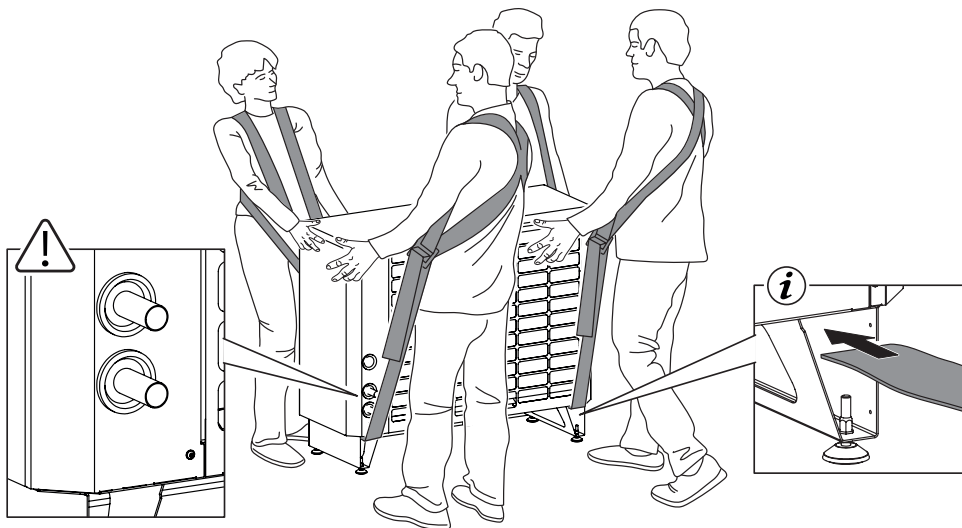

WARNING!

- Ensure that a sufficient number of people help to lift the heat pump from the pallet onto the foundation. Check the weight of the product, which is stated in the chapter "Technical Data".
- The heat pump's centre of gravity is offset to the right side of the product, seen from the front.
- Take care that the protruding primary flow and return pipes, as well as the electric cables on the back of the heat pump, are not damaged during lifting.
- The heat pump must never be moved by taking hold of the front of the product.
- Check before installing that the heat pump has not been damaged during transportation. Report any transport damage to the carrier.
- Place the heat pump on a solid foundation, preferably concrete. If the heat pump needs to be placed on soft matting, base plates must be placed under the adjustable feet.

- Place the heat pump so that air does not recirculate to the evaporator. If the heat pump is in a raised position, protection to prevent recirculation under the product must be installed.
- Place the heat pump so that a safety area can be established in its vicinity; see the section "Safety area" in the chapter "Safety Regulations — Flammable Refrigerants, safety group A3".
- Remember that there must be a service space of at least one metre on each side of the heat pump.

3.3 Recycling

- The packaging must be deposited at a recycling station or with the installer for correct waste management.
- Obsolete products must be disposed of correctly and transported to a waste station or distributor/retailer offering this service. Disposing of the product as household waste is not permitted.

Note!

The product contains a flammable refrigerant.

- It is very important that the product's refrigerant, compressor oil and electric/electronic components are disposed of correctly.

3.4 After commissioning

- The installer advises the property owner on the construction and servicing of the system.
- The installer completes the checklist on the previous page and enters contact information - the customer and installer sign the list, which is saved by the customer.
- Register the product for warranty and insurance via the website 'www.ctc-heating.com'.

When contacting customer service, always mention the following:

- Serial number
- Model/size
- The fault message shown in the display
- Your telephone number

Serial number

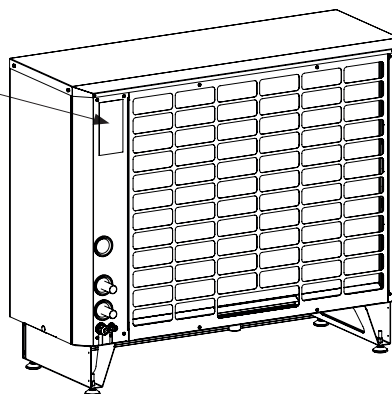

Fill in the information below. It may be useful if anything should happen.

Product:	Serial number:
Pipe installer:	Name:
Date:	Tel. no.:
Electrical installer:	Name:
Date:	Tel. no.:

No liability is accepted for any misprints. We reserve the right to make design changes.

4. Safety Regulations — Flammable refrigerants, safety group A3

Annex DD, standard EN 60335-2-40

Annex DD in standard EN 60335-2-40 establishes requirements for information in the instruction manual for the installation, service and maintenance of equipment that contains flammable refrigerants.

Safety symbols

This symbol warns of personal injury.



This symbol warns of personal injury, specifically fire/explosion hazards.



Note!

Information that is marked with the word “Note!” provides further information.

General



- Do not speed up the defrosting process more than is recommended by the manufacturer.
If ice forms anywhere on the product, it must not be broken loose but removed with lukewarm water.
- During storage, the heat pump must be placed in a room without sources of ignition (for example, open flames, gas source in operation or immersion heater in operation) and with a sufficiently large floor surface.
- The cooling circuit with refrigerant must not be drilled into or heated up.
- Remember that refrigerants may be odourless.
- The heat pump must be installed and commissioned outdoors at a distance from the outer wall according to the chapter “Safety area”. During indoor storage, the space must be a minimum 26 m² and well ventilated.

General information



WARNING!

The heat pump contains the flammable refrigerant R290 (propane C_3H_8). In the event of leakage, a flammable or explosive atmosphere is formed with the surrounding air.

Gas leaks may lead to explosions, resulting in very severe personal injury and death. Risk of suffocation by inhalation.

The cooling circuit with refrigerant is an integrated part of the heat pump, which is installed by CTC at the factory. The cooling circuit must not be modified.

Only CTC-approved components must be used if safety-critical components in the system are to be replaced; see also the section "Service works".

For more information on maintenance, cleaning and preventative maintenance of the heat pump, see the chapter "Operation and maintenance".

For more information on setup and commissioning of the heat pump, see the chapter "Installation".

Non-ventilated spaces

The heat pump must be installed and commissioned outdoors.

During storage, the heat pump must be placed in a room without sources of ignition (for example, open flames, gas source in operation or immersion heater in operation) and with a sufficiently large floor surface.

The heat pump must be stored so that no mechanical damage can occur.

Qualifications, authorised personnel

Work on a cooling circuit with flammable refrigerant may only be performed by authorised personnel with applicable certificates in handling flammable refrigerants from a competent authority that is recognised in the industry.

Service must only be performed according to the manufacturer's recommendations; see the chapter "Operation and maintenance".

Maintenance and repair work that requires the help of personnel with another competence must be performed under the supervision of personnel who are authorised to handle flammable refrigerants.

Service works

Check of the work area



WARNING!

Before service work on installations that contain flammable refrigerants is started, safety checks must be performed to minimise the risk of the refrigerant igniting.

A risk assessment should always be carried out when performing measures or working on the refrigeration system, based on the conditions of each individual case, such as ventilation, space, etc.

Work process

Service work must be performed according to a predetermined process in order to minimise the risk of flammable gas or vapour leaking out during the work process.

General, work in the vicinity

All maintenance personnel and other people working in the vicinity must be informed of the risks that the service works involve. Work in confined spaces must be avoided. The service area must be segregated. Ensure that the area is safe before work with flammable material.

Detecting refrigerant

The area must be checked with a suitable refrigerant detector before and during the work so that the service technician can be certain that there is no refrigerant leakage. Ensure that the detection equipment is suitable for use when working with flammable refrigerants so that, for example, no sparking can occur from the equipment, or that it is sufficiently well sealed or explosion-proof.

Fire extinguishers

Suitable fire extinguishing equipment must be available, for example, dry powder or CO₂ fire extinguishers, in heat-generating service works or in connection with installation of the heat pump.

No sources of ignition

No sources of ignition may be used in such a way that they could cause a risk of fire or explosion in service works in connection with the heat pump. All possible sources of ignition, including smoking, should be kept a sufficient distance from the workplace due to the risk of release of refrigerant in the vicinity. Before starting work, the vicinity must be examined to ensure that there are no fire hazards or ignition risks. Signage must state that smoking is prohibited.

Ventilated service area

Service works must be performed outdoors or in a space that is sufficiently ventilated during the time that work is ongoing. The ventilation must safely ensure that any released refrigerant is taken care of and released into the atmosphere.

System checks

If electrical components in connection with the refrigerant need to be replaced, the replacement components must be equivalent in function and specification. CTC's guidelines for maintenance and service must always be followed. If in doubt, contact CTC's technical support department.

Check of electrical components

Repair and maintenance of electrical components must be preceded by safety checks and procedures for inspecting the components. In the event of a fault that may endanger safety, the power must not be connected until the fault has been remedied. If the fault cannot be remedied immediately and continued operation of the system is important, a suitable temporary solution may be used. This must be reported to the owner of the equipment.

Initial safety checks must include:

- Checking that capacitors are discharged; this must be performed in a safe way to avoid the risk of sparking.
- Ensuring that no electrical components or cabling are exposed during evacuation or filling of refrigerant.
- Checking that earthing is intact.

Repair of sealed electrical components



WARNING!

When repairing sealed electrical components, the heat pump must first be disconnected from the power source before removing the protective covering of the sealed components. If a power supply to the heat pump is necessary during the service case, a leak detector solution must be used at the most critical site in order to warn of a potentially dangerous situation.

After service works with electrical components, ensure that their protective coverings have not been affected. Also check that no damage to cables or gaskets has occurred. No further electrical connections may be added.

Ensure that installation occurs in a safe manner.

Ensure that gaskets are intact and fulfil the protective function in a flammable environment. Replacement components must fulfil the manufacturer's specifications.

Repair of intrinsically safe components



WARNING!

Do not apply any permanent inductive or capacitance loads to the circuit without ensuring that this will not exceed the permissible voltage and current permitted for the equipment.

Only intrinsically safe components can be worked with in a flammable atmosphere. Ensure that the test equipment has correct classification.

Replacement components must fulfil the manufacturer's specifications. Other parts may cause ignition of refrigerant in the atmosphere due to leakage.

Note!

Use of silicon sealant may limit the efficacy of certain types of leak detection equipment. Explosion-proof components do not need to be isolated before starting work on them.

Cabling



WARNING!

Check that cables are not subject to wear, corrosion, increased pressure, vibrations, sharp edges or are affected by environmental factors. During the check, the effects of age/wear or impact from continuous vibration sources, such as compressors and fans, must also be assessed.

Leak detection, detection of flammable refrigerants



WARNING!

Under no circumstances may sources that could potentially be ignited be used to detect refrigerant leaks. Leak detectors that use open flames must not be used.

Leak detection methods



WARNING!

The leak detection methods stated below are considered acceptable for cooling systems with flammable refrigerants.

Electronic leak detectors must be used to detect refrigerant leaks; however, the sensitivity may be inadequate and the detectors may need to be recalibrated (in a refrigerant-free area). Ensure that the detector is not a potential source of ignition and is suitable for use with the relevant refrigerant. The leak detection equipment must be set to a percentage of the refrigerant's LFL (ignition limit) and be calibrated against the refrigerant so that a suitable percentage of gas (maximum 25%) can be established.

Lead detection fluids are also suitable for use together with the majority of refrigerants; however, the use of fluids that contain chlorine must be avoided, as the chlorine can react with the refrigerant and corrode the copper pipes.

If refrigerant leakage is suspected, all open flames must be removed/ extinguished.

If refrigerant leakage is detected that requires soldering, all refrigerant must be recovered from the system or isolated (with the aid of shut-off valves) in a part of the system that is sited far from the leak. Oxygen-free nitrogen (OFN) must then be purged through the system both before and during the soldering process.

Empty and evacuate refrigerant



WARNING!

Once the refrigerant circuit is opened to perform repairs, or for any other reason, conventional processes must be applied. It is important that best practices are followed for flammable refrigerants. The following process must be followed:

- Empty the cooling circuit of refrigerant.
- "Purge" the circuit with inert gas (a gas that does not chemically react with its surroundings).
- Evacuate.
- "Purge" the cooling circuit again with inert gas.
- Open the cooling circuit by cutting or soldering.

The refrigerant must be recovered in appropriate recovery cylinders. The system must be "purged" with oxygen-free nitrogen (OFN) to make the unit safe. This process may need to be repeated several times. Compressed air or oxygen must not be used.

"Purging" of the refrigerant circuit must be carried out so that the vacuum in the system is breached with OFN. Then continue to fill the circuit until its working pressure is reached, bleed to atmospheric pressure, and finally reduce the pressure to vacuum. This process must be repeated until no refrigerant remains in the system. Once the final OFN purging has been performed, the system pressure must be reduced to atmospheric pressure so that work can be started. This procedure is absolutely necessary if soldering to pipelines is to occur.

Ensure that the outlet of the vacuum pump is not near any potential sources of ignition and that the ventilation is good.

Filling of refrigerant



WARNING!

In addition to conventional filling processes, the following requirements must be met.

- Ensure that contamination by other refrigerants does not occur when using the filling equipment. Hoses or leads must be as short as possible in order to limit the amount of refrigerant that they contain.
- Cylinders must be stored in a safe manner in accordance with the instructions.
- Ensure that the cooling system is earthed before filling the system with refrigerant.
- Label the cooling system once the filling is complete (if it has not already been labelled).
- Show utmost caution not to overfill the cooling system.

Before the system is filled again, it must be pressure tested with appropriate purge gas. The system must be tested for leakages after filling but before commissioning. A follow-up leakage test must be performed before the work is ended.

Evacuation of refrigerant



WARNING!

Before this process is performed, it is important that the service technician be completely familiar with the equipment and its function. The refrigerant must be recovered in a safe manner. When reusing recovered refrigerant, an oil and refrigerant test must be performed (if such an analysis is required) before evacuating the refrigerant. An electrical connection must be available before starting the process.

- a. Familiarise yourself with the equipment and its function.
- b. Isolate the system electrically.
- c. Before starting the process, ensure that:
 - Equipment for handling refrigerant cylinders is available, if required.
 - All personal protective equipment is available and used correctly.
 - The evacuation process is monitored at all times by an authorised person.
 - Evacuation equipment and refrigerant cylinders fulfil relevant standards.
- d. Reduce the pressure in the cooling system, if possible.
- e. If it is not possible to achieve vacuum pressure, use a pipe solution so that refrigerant can be evacuated from different parts of the system.
- f. Ensure that the refrigerant cylinder is placed on a scale before evacuation occurs.
- g. Start the evacuation equipment and use it in accordance with the instructions.
- h. The cylinders must not be overfilled (maximum 80% fluid volume).

- a. The cylinders' maximum work pressure must not be exceeded in any event.
- b. Once the bottles are correctly filled and the process is ended, ensure that the cylinders and evacuation equipment are immediately moved from the site and that all shut-off valves on the equipment have been closed.
- c. Recovered refrigerant must not be filled into another cooling system that has not been cleaned and checked first.

Labelling

The heat pump must be equipped with a label that shows that it has been decommissioned and emptied of refrigerant. The label must be dated and signed. Ensure that there are labels on the equipment that state that the equipment contains flammable refrigerant.

Recovery of refrigerant



WARNING!

Once a refrigerant has been evacuated from the heat pump, either in service or upon scrapping, it is good practice for the refrigerant to be recovered in a safe manner.

When transferring refrigerant to cylinders, ensure that only intended recovery cylinders are used. Ensure that the total number of cylinders required are available to handle the total volume of refrigerant in the cooling system. All relevant cylinders must be intended for the refrigerant that is recovered and be labelled for this refrigerant (i.e. special cylinders that are suitable for the recovery of refrigerant). The cylinders must be equipped with a pressure relief valve and associated shut-off valves in a well functioning state. Empty cylinders must be evacuated of any refrigerant and, if possible, cooled before they are filled during recovery.

The recovery equipment must be in good condition with setup instructions for the equipment on hand. The equipment must be suitable for the recovery of flammable refrigerants. In addition, a set of calibrated scales must be available and in good condition. Hoses must be equipped with leakage-free disconnections and be in good condition. Before using the recovery equipment, check that it is in a satisfactory condition, has been well maintained and that all associated electrical components are sealed to prevent ignition in the event of refrigerant release. Contact CTC if you are unsure.

The recovered refrigerant must be returned to the refrigerant supplier in appropriate recovery cylinders and a relevant document for waste transport ("Waste Transfer Note") must be created. Do not mix different refrigerants in recovery containers and particularly not in the refrigerant cylinders.

If a compressor or compressor oil has to be recovered, ensure that they have been evacuated to an acceptable level to ensure that no flammable refrigerant remains in the lubricant. The compressor must be evacuated before disposal and transported to a waste station or retailer/distributor who provides this type of service. Only electrical heating of the compressor may be used to accelerate this process. When oil is drained from a system, this must occur in a safe manner.

Safety area



WARNING!

The images show the safety area (A) that applies to the heat pump.

The following conditions must not occur within the safety area:

- Openings in the building, e.g. windows, doors, light sources or skylights.
- Air supply from ventilation and air conditioning systems.
- Property borders, adjacent property, walkways and other roads.
- Pump shafts, inflow to the drainage system without water traps, downpipes and sewage trenches etc.
- Other troughs, wells, recesses, shafts.
- Electrical connections to the building.
- Electrical systems, plug sockets, lights, switches.
- Snowfall from roofs.

Do not introduce sources of ignition in the safety area:

- Open flames or burner assemblies.
- Grills/barbecues.
- Sparking tools.
- Electrical equipment with sources of ignition, mobile units with inbuilt batteries (e.g. cars, mobile telephones, fitness trackers etc.).
- Objects with a temperature exceeding 360 °C.

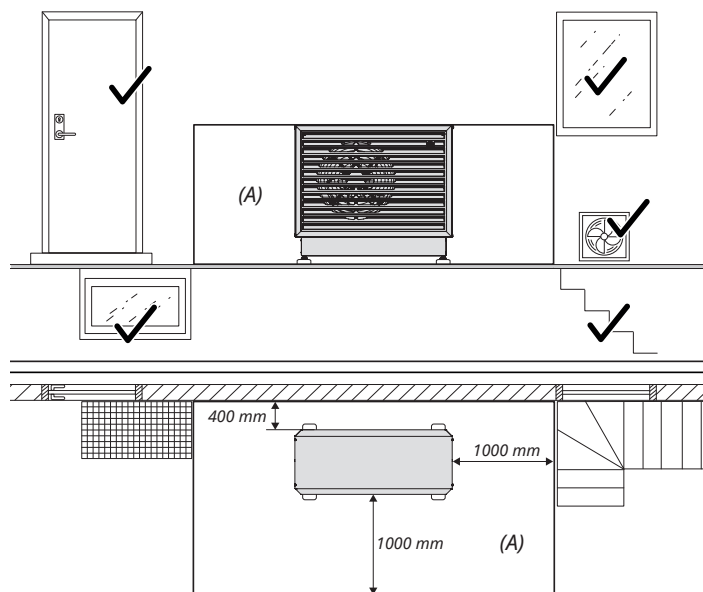

The heat pump's safety area (A), placement against a wall.

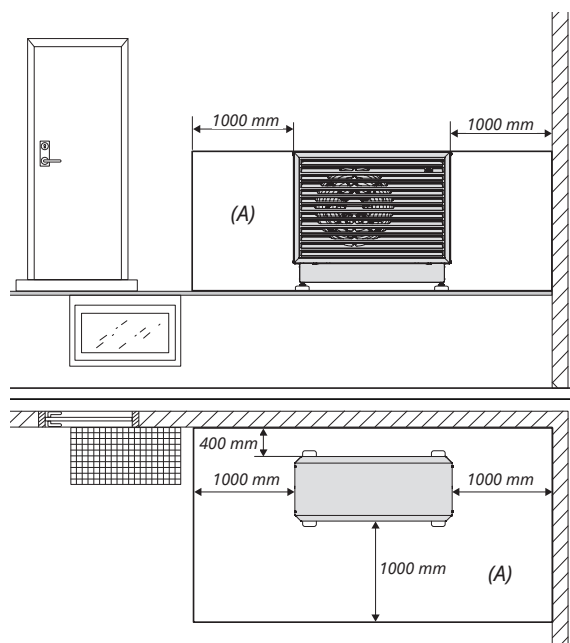

The heat pump's safety area (A), placement in a corner.

Safety equipment



WARNING!

- When handling the product with a hoist ring or similar device, make sure that the lifting equipment, eyebolts and other parts are not damaged. Never stand under the hoisted product.
- Never jeopardise safety by removing bolted covers, hoods or similar.
- Never jeopardise safety by deactivating safety equipment.

Note!

- The product is classed as IPX4 and is approved for outdoor use.
- This device can be used by children from the age of eight years and above, and by people with reduced physical, sensory or mental ability or lack of experience or knowledge, if they have been taught, either with supervision or with the instructions provided, how to use the device safely and understand the risks involved. Children should not play with the device. Cleaning and maintenance should not be carried out by children without supervision.
- If these instructions are not followed when installing, operating and maintaining the system, CTC's commitment under the applicable warranty terms is not binding.

5. Connection alternatives

Various connection alternatives for CTC EcoAir 700M are shown below.

! Control products must have program version 2023-11-01 or later.



**can also deliver cooling together with CTC EcoAir 700M*

6. Technical data

		EcoAir 708M	EcoAir 712M
Article number		590500001 (3x400V) 590501001 (1x230V)	590510001 (3x400V) 590511001 (1x230V)
Product data number (GTIN/EAN)		7333077103705 (3x400V) 7333077103743 (1x230V)	7333077103712 (3x400V) 7333077103750 (1x230V)
HP-Keymark		012-C700200	012-C700200
General data			
Weight (gross) / Weight (net)	kg	189 / 164 (3x400V) 185 / 160 (1x230V)	189 / 164 (3x400V) 185 / 160 (1x230V)
Dimensions (DxWxH), package excluded	mm	510 x 1248 x 1068	510 x 1248 x 1068
Dimensions (DxWxH), package included	mm	802 x 1325 x 1217	802 x 1325 x 1217
Packaged volume	m ³	1,29	1,29
Ingress Protection class (IP)		IP X4	IP X4
Capacity			
Heating capacity max: W35 & A +12/+7/+2/-7/-15	kW	8,71 /6,96 /5,66 /5,51 /4,13	11,23 /9,04 /7,36 /7,11 /6,24
Heating capacity nominal: W35 & A +12/+7/+2/-7/-15	kW	5,8 /4,95 /3,84 /3,23 /2,52	5,8 /4,95 /3,84 /3,23 /2,52
Heating capacity min: W35 & A +12/+7/+2/-7/-15	kW	2,32 /1,99 /2,07 /- /-	2,32 /1,99 /2,07 /- /-
Power input max: W35 & A +12/+7/+2/-7/-15	kW	1,82 /1,72 /1,62 /1,75 /1,62	2,6 /2,63 /2,54 /2,08 /2,74
Power input nominal: W35 & A +12/+7/+2/-7/-15	kW	0,99 /1,02 /0,98 /0,99 /0,95	0,99 /1,02 /0,98 /0,99 /0,95
Power input min: W35 & A +12/+7/+2/-7/-15	kW	0,37 /0,4 /0,48 /- /-	0,37 /0,4 /0,48 /- /-
COP max: W35 & A +12/+7/+2/-7/-15		4,78 /4,05 /3,49 /3,15 /2,55	4,33 /3,44 /2,9 /2,54 /2,27
COP nominal: W35 & A +12/+7/+2/-7/-15		5,86 /4,87 /3,91 /3,26 /2,64	5,86 /4,87 /3,91 /3,26 /2,64
COP min: W35 & A +12/+7/+2/-7/-15		6,26 /5,01 /4,34 /- /-	6,26 /5,01 /4,34 /- /-
Speed control, min-max	RPS	20-80	20-120
Nominal speed A7/W35 & A7/W55	RPS	50	50
Cooling capacity			
Cooling capacity max: A35 & W18/W7	kW	7,53 /5,65	7,53 /5,65
Cooling capacity nominal: A35 & W18/W7	kW	5,24 /3,79	5,24 /3,79
Cooling capacity min: A35 & W18/W7	kW	1,56 /0,94	1,56 /0,94
Power input max: A35 & W18/W7	kW	2,57 /2,34	2,57 /2,34
Power input nominal: A35 & W18/W7	kW	1,3 /1,25	1,3 /1,25
Power input min: A35 & W18/W7	kW	0,35 /0,36	0,35 /0,36
EER max: A35 & W18/W7		2,93 /2,42	2,93 /2,42
EER nominal: A35 & W18/W7		4,02 /3,04	4,02 /3,04
EER min: A35 & W18/W7		4,42 /2,59	4,42 /2,59
Speed control, min-max	RPS	20-80	20-80
Ratingdata HP Keymark			
Rating point at W35	RPS	50	50
Heating capacity at rating point: W35	kW	4,95	4,95
Power input at rating point: W35	kW	1,02	1,02
COP at rating point: W35		4,87	4,87
Flow qw at rating point: W35	m ³ /h	0,85	0,85
Rating point at W55	RPS	50	50
Heating capacity at rating point: W55	kW	4,78	4,78
Power input at rating point: W55	kW	1,46	1,46
COP at rating point: W55		3,28	3,28
Flow qw at rating point: W55	m ³ /h	0,52	0,52

Sound data		EcoAir 708M	EcoAir 712M
Sound power L_{WA} A7/W35 (EN 12102)	dB(A)	46	47
Sound power L_{WA} A7/W55 (EN 12102)	dB(A)	46	47
Minimum sound power A7/W35 (EN 12102)	dB(A)	46	47
Maximum sound power A7/W35 (EN 12102)	dB(A)	55	59
Sound pressure L_{pA} 5m A7/W35	dB(A)	27	28
Sound pressure L_{pA} 10m A7/W35	dB(A)	21	22
Sound power L_{WA} A2/W30 (EN 12102 & EN 14825)	dB(A)	47,5	51
Warm side			
Maximum operation pressure (PS)	bar	3	3
Water volume (V)	liter	2,9	2,9
Safety valve	bar	2	2
Maximum operating temperature (TS)	°C	100	100
Water volume, condenser	liter	2,04	2,04
Flow qw nominal: A7/W35, $\Delta t = 5$ K	l/s	0,2294	0,2294
Flow qw minimum: A7/W35 at defrost	l/s	0,1667	0,1667
Minimum allowed system temperature at defrost	°C	25	25
Other			
Air flow: silent mode max	m ³ /h	2787	2815
Air flow	m ³ /h	2787	2787
Air flow: max	m ³ /h	3041	3340
Refrigerant, type		R290	R290
Refrigerant, charge	kg	0,8	0,8
GWP value		0,02	0,02
CO ₂ - equivalent	ton	0,000016	0,000016
Pressure limiter, high pressure	bar	31±0,7	31±0,7
Low pressure sensor	bar	0-10	0-10
Maximum operating pressure, high pressure side (PS)	bar	31	31
Maximum operating pressure, low pressure side (PS)	bar	31	31
Theoretical displacement of the compressor	cm ³ /rev	30,6	30,6
Compressor type		Twin rotary	Twin rotary
Seasonal coefficient of performance data			
SCOP / $P_{designh}$ / η , cold climate W35 (EN14825, $P_{designh}$)		4,25 / 6 / 166,8	4,24 / 8 / 166,5
SCOP / $P_{designh}$ / η , cold climate W55 (EN14825, $P_{designh}$)		3,43 / 6 / 134,1	3,38 / 8,4 / 132,1
SCOP / $P_{designh}$ / η , average climate W35 (EN14825, $P_{designh}$)		5,04 / 5,3 / 198,3	5,00 / 7,3 / 197,0
SCOP / $P_{designh}$ / η , average climate W55 (EN14825, $P_{designh}$)		3,83 / 5 / 150,8	3,86 / 7 / 151,2
SCOP / $P_{designh}$ / η , warm climate W35 (EN14825, $P_{designh}$)		6,16 / 5,7 / 243,2	6,07 / 7,5 / 239,9
SCOP / $P_{designh}$ / η , warm climate W55 (EN14825, $P_{designh}$)		4,67 / 5,7 / 183,9	4,48 / 7,5 / 176,3

6.1 Electrical data

6.1.1 400V 3N~

Rated electrical data		EcoAir 708M, 3x400V	EcoAir 712M, 3x400V
		400V 3N~ 50Hz	400V 3N~ 50Hz
Rated power input	kW	3,1	5,3
Rated current	A	4,7	8
Group fuse max	A	16	16
Maximum starting current	A	1,1	1,1
Reactive power or power factor at min. rps	cosΦ	-0,56	-0,56
Reactive power or power factor at max. rps	cosΦ	-0,96	0,98
Input power, fan	W	12 / 36 / 153 / 170	12 / 36 / 153 / 170
Dimension power cable	mm ²	2,5	2,5

6.1.2 230V 1N~

Rated electrical data		EcoAir 708M, 1x230V	EcoAir 712M, 1x230V
		230V 1N~ 50Hz	230V 1N~ 50Hz
Rated power input	kW	3,3	3,68
Rated current	A	16	16
Group fuse max	A	16	16
Maximum starting current	A	1,8	1,8
Reactive power or power factor at min. rps	cosΦ	-0,86	-0,86
Reactive power or power factor at max. rps	cosΦ	-0,98	0,99
Input power, fan	W	12 / 36 / 153 / 170	12 / 36 / 153 / 170
Dimension power cable	mm ²	2,5	2,5

7. Dimensional drawing

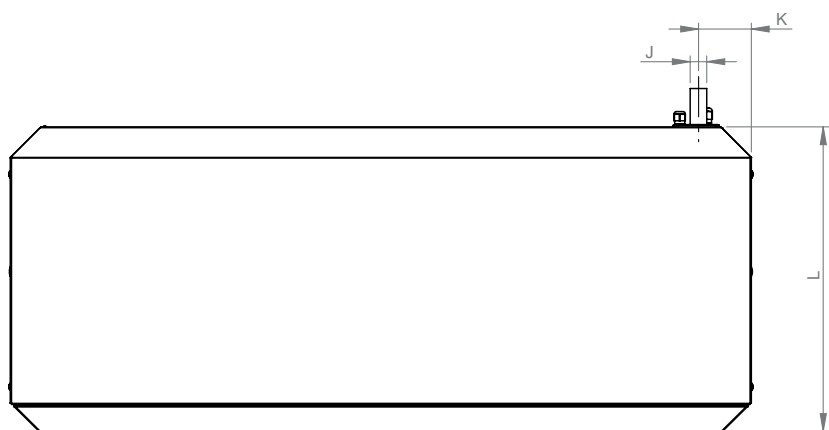
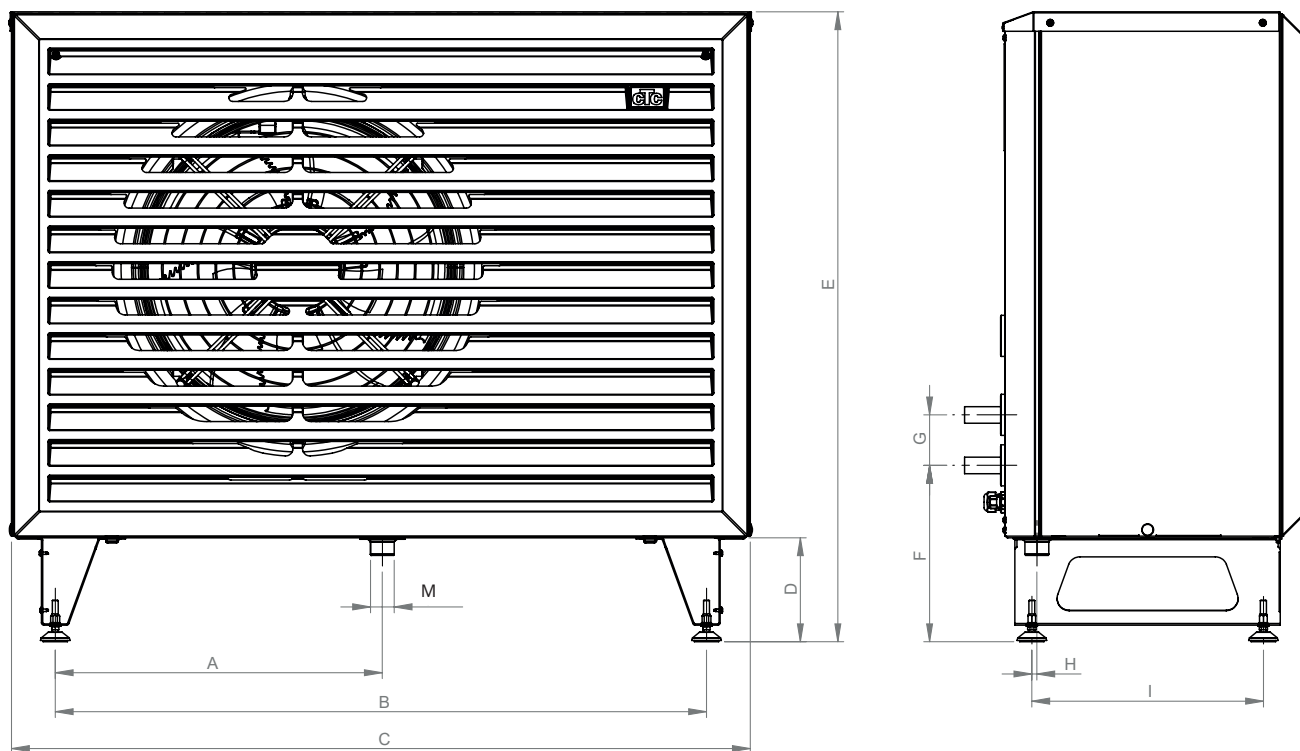

EcoAir 708M / 712M	
	mm
A	551
B	1096
C	1248
D	175
E	1068
F	297
G	85
H	8
I	390
J	28
K	87
L	510
M	40

8. Component placement

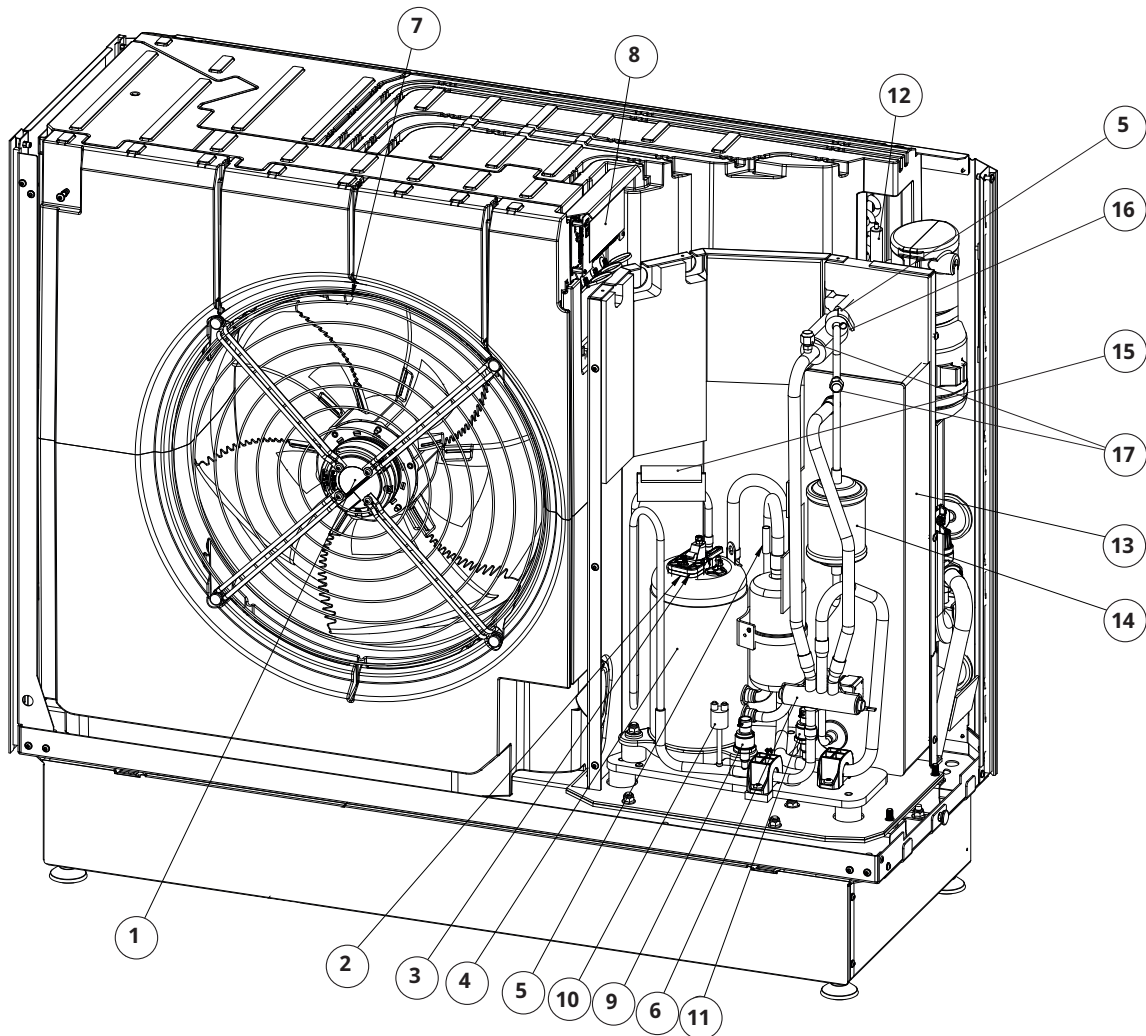

- | | | | |
|-----|----------------------|-----|----------------------------------|
| 1. | Fan | 11. | Low pressure sensor |
| 2. | Compressor sensor | 12. | Expansion valve |
| 3. | Thermal switch | 13. | Condenser |
| 4. | Compressor | 14. | Drying filter |
| 5. | Suction gas sensor | 15. | Hot gas sensor |
| 6. | Four-way valve | 16. | Temperature sensor, liquid line |
| 7. | Outgoing air sensor | 17. | Service connections ("Schrader") |
| 8. | Circuit board I/O | | |
| 9. | High pressure sensor | | |
| 10. | High pressure switch | | |

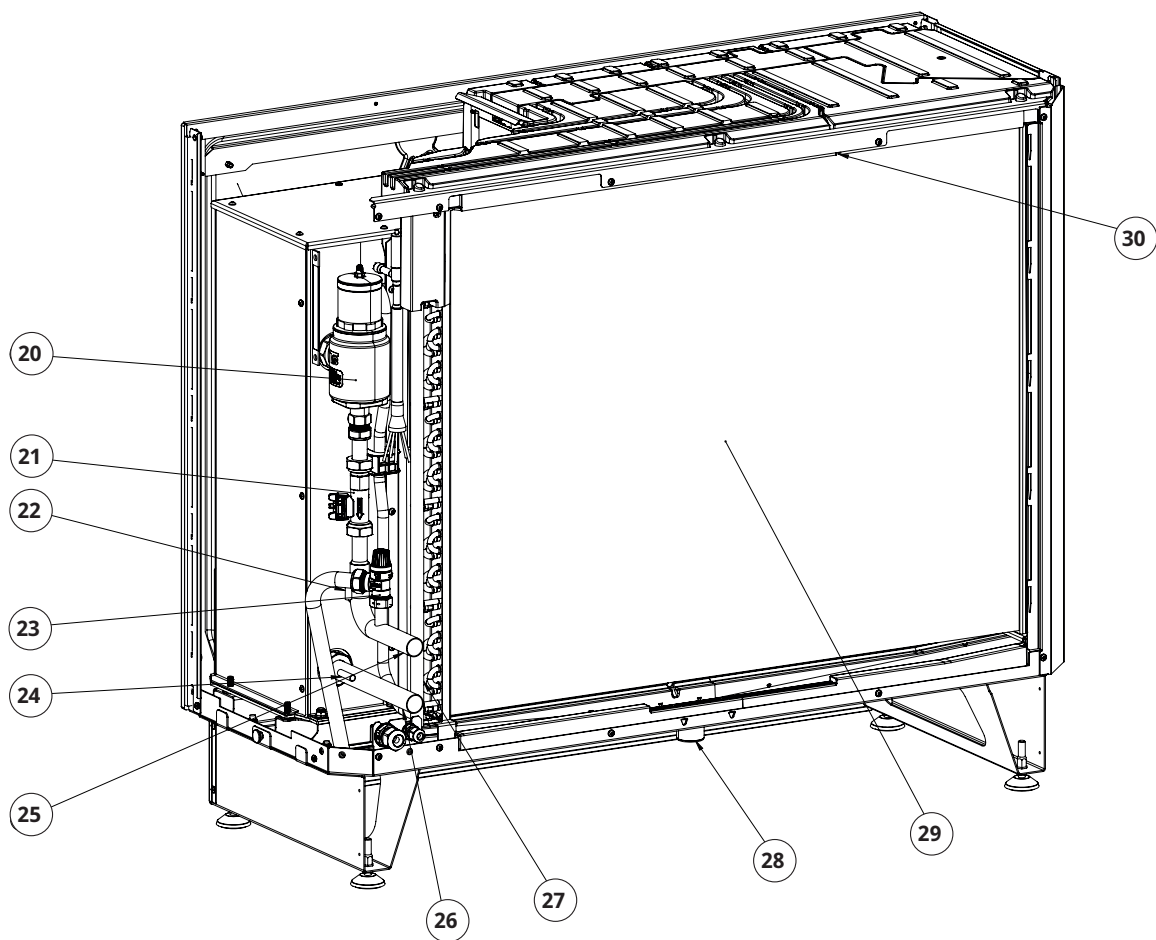

- 20. Gas/air separator
- 21. Flow sensor
- 22. Primary flow sensor, water out
- 23. Safety valve (2 bar)
- 24. Return flow sensor, water in
- 25. Primary flow Ø28 mm
- 26. Return flow Ø28 mm
- 27. Defrosting sensor
- 28. Condensate drain
- 29. Evaporator
- 30. Outdoor sensor

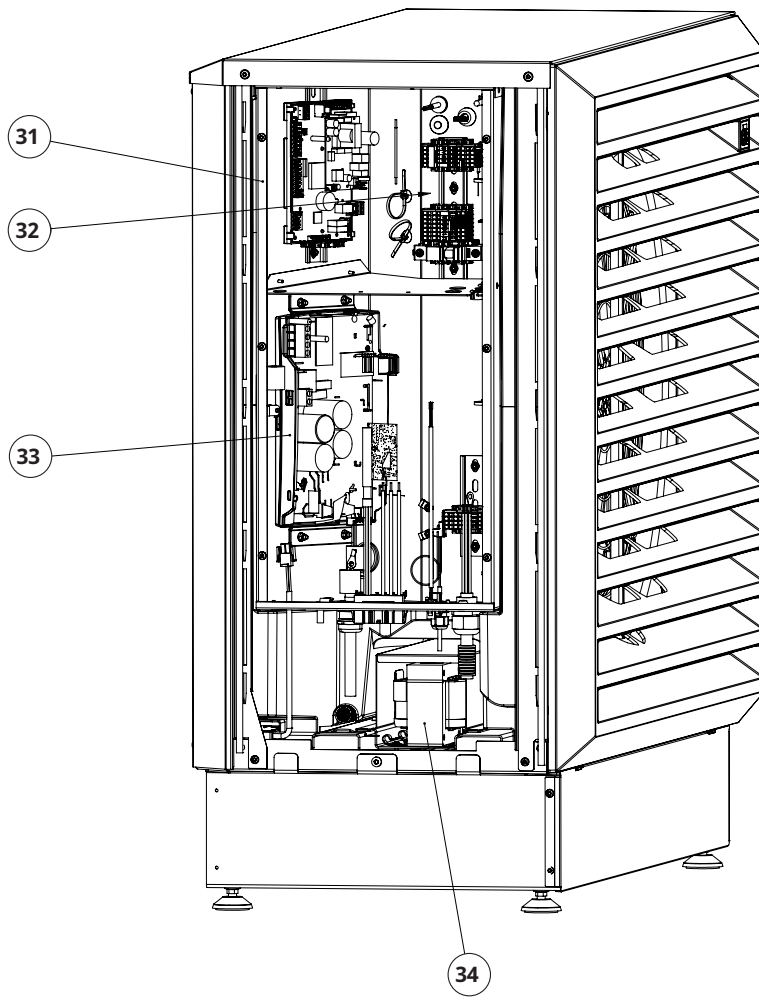

- 31. Electrical cabinet
- 32. Communication
- 33. Frequency converter (Driver)
- 34. AC coil (x3)

8.1 Refrigerant system

Flow chart CTC EcoAir 700M

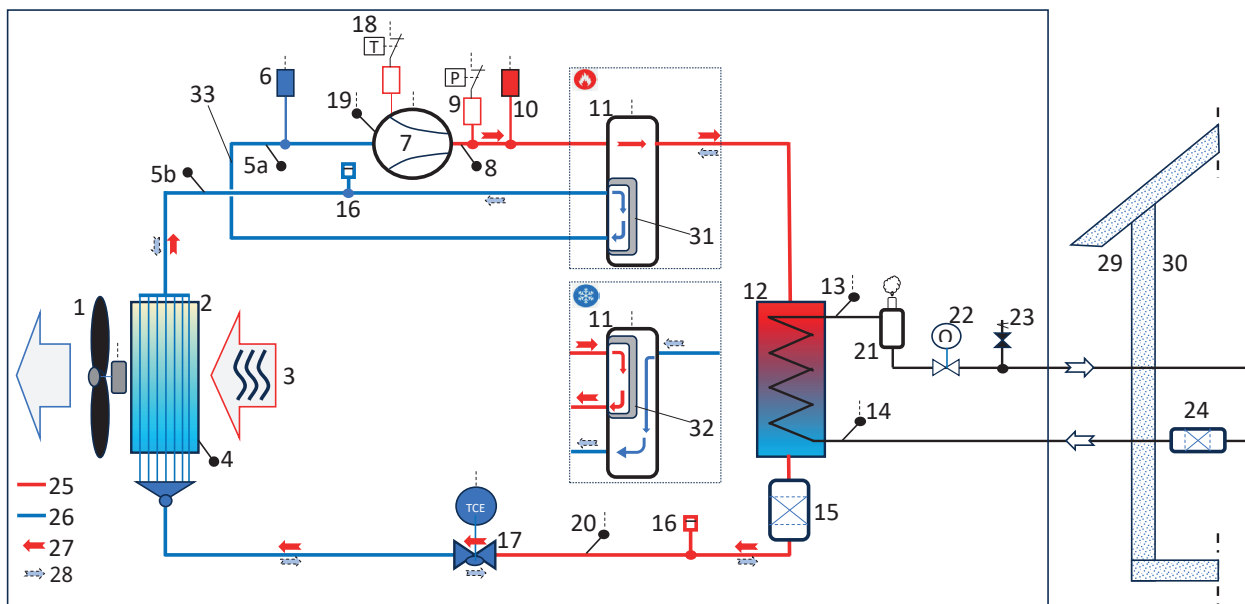

- | | |
|---|--|
| 1. Fan (M10) | 19. Temperature sensor, compressor (B62) |
| 2. Evaporator | 20. Temperature sensor, liquid line (B111) |
| 3. Outdoor air | 21. Gas separator, heating circuit |
| 4. Defrosting sensor (B16) | 22. Flow sensor, heating circuit (B48) |
| 5. Suction gas sensor 1/2 (B22) | 23. Safety valve, heating circuit |
| 6. Low pressure sensor (B101) | 24. Particle filter, heating circuit |
| 7. Compressor (M1) | 25. High pressure (in heating mode) |
| 8. Hot gas sensor (B21) | 26. Low pressure (in heating mode) |
| 9. High pressure switch (F20) | 27. Direction of refrigerant flow in heating mode |
| 10. High pressure sensor (B100) | 28. Direction of refrigerant flow in defrosting/cooling mode |
| 11. Four-way valve (Y11) | 29. Outdoor |
| 12. Condenser | 30. Indoor |
| 13. Primary flow sensor (B1), water out | 31. Position of four-way valve in heating mode |
| 14. Return flow sensor (B7), water in | 32. Position of four-way valve in defrosting/cooling mode |
| 15. Drying filter | 33. Refrigerant piping |
| 16. Service connections ("Schrader") | |
| 17. Expansion valve (Y10) | |
| 18. Thermal switch (B106) | |

9. Operating range

CTC EcoAir 700M control system monitors and ensures that the heat pump is working within its operating range.

The figures below show graphs of the heat pump operating range in heating and cooling mode.

9.1 Operating range, heating

Water temperature °C

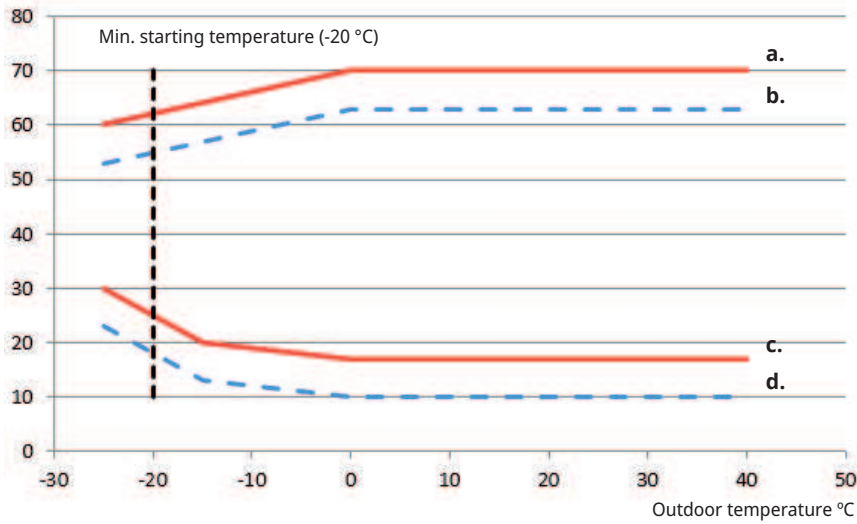

9.2 Operating range, cooling

Water temperature °C

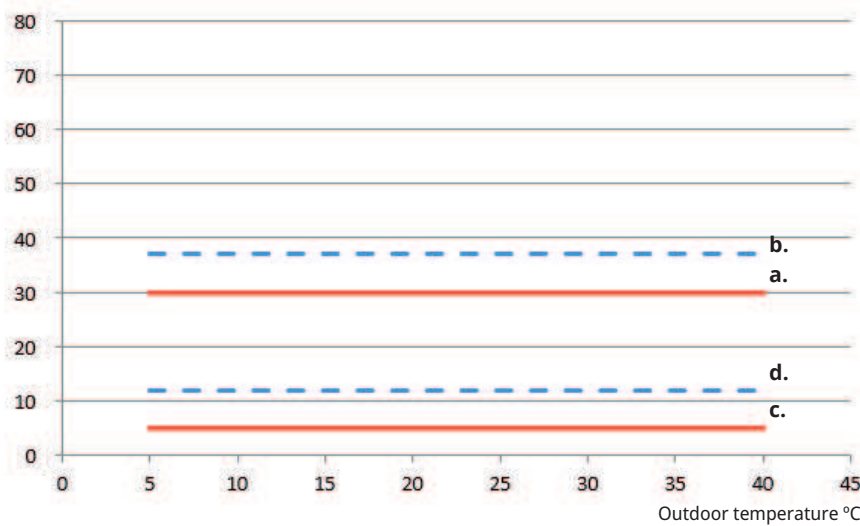

a.	Max. temperature primary flow °C
b.	Max. temperature return flow °C
c.	Min. temperature primary flow °C
d.	Min. temperature return flow °C

10. Compressor speed limitation, heating

The figure below shows the maximum compressor speed (RPS) for EcoAir 700M in heating mode except for the lower graph, which shows minimum compressor speed in the operating range.

The compressor speed is limited by the control system so that max. current does not exceed 16A.

Note the difference between the graphs of the EcoAir 712M (1x230V) and the EcoAir 712M (3x400V) due to current limitations.

Depending on the control product, the compressor speed during DHW charging can in some cases be limited (and charging times therefore longer).

10.1 EcoAir 708M

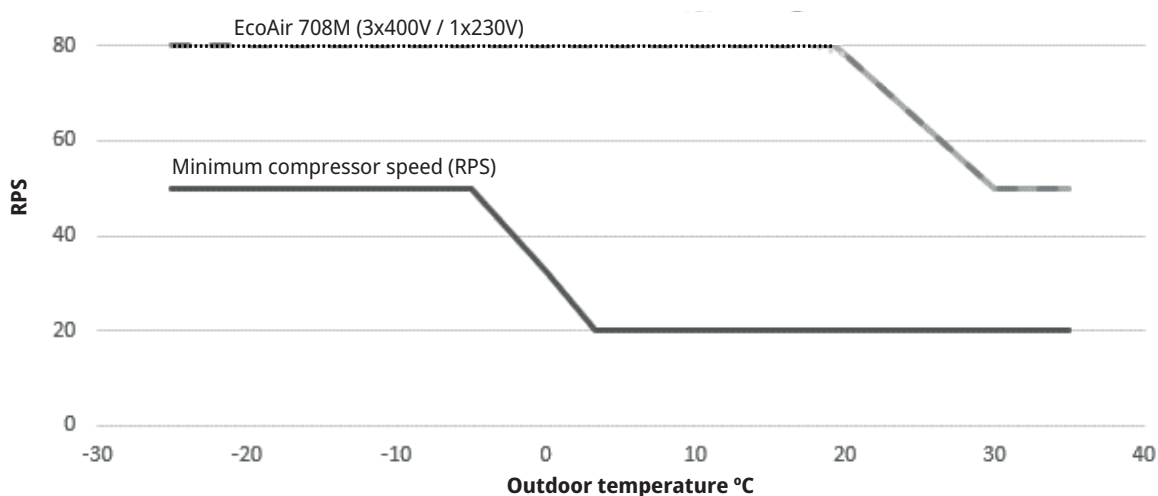

10.2 EcoAir 712M

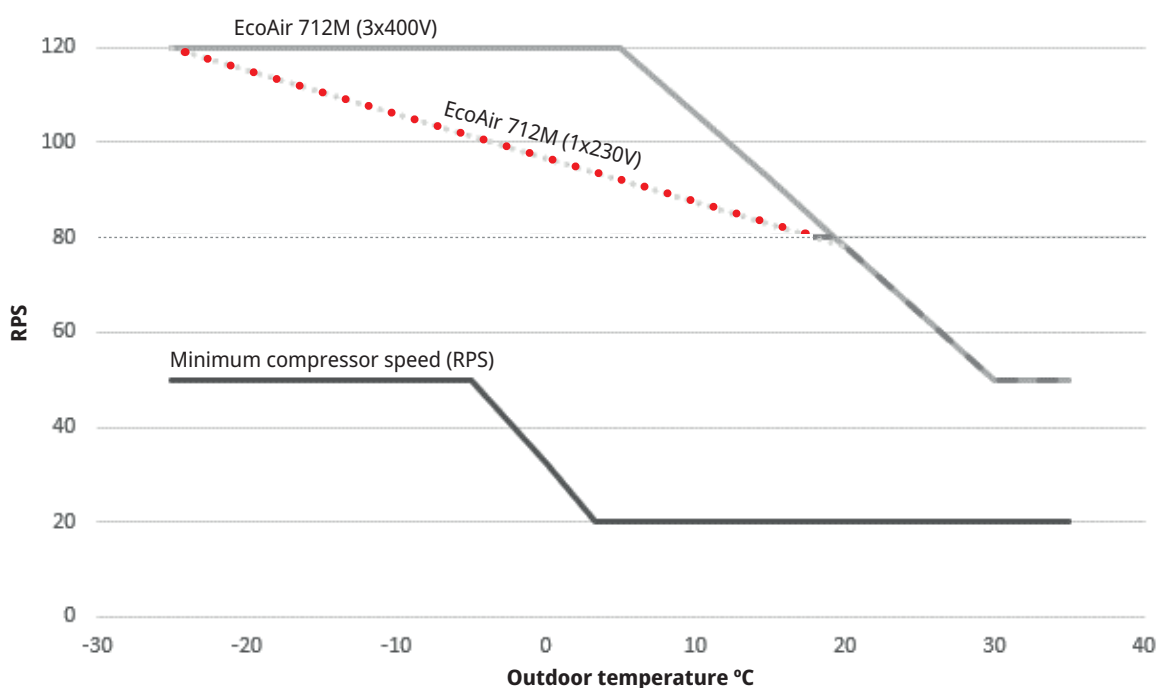

11. Installation

This section is aimed at anyone responsible for one or more of the installations required in order to ensure that the product works the way the property owner wants.

Only set up the heat pump outdoors in accordance with applicable regulations.

Installation must occur in accordance with national and/or local regulations.

As the heat pump's cooling circuit contains highly flammable refrigerant, a safety area must be established around the heat pump's immediate surroundings. See the chapter "Safety area".

11.1 Included in the delivery

- Heat pump CTC EcoAir 700M.
- Enclosed components: Filter ball valve: G1", Cover plate*, Installation and maintenance manual.
- 15 m cable LiYCY-TP (2x2x0,75 mm²) with connector for communication, fitted.
- 2 m power cable (2,5 mm²), fitted.

11.2 Placement of the heat pump



WARNING!

- Place the heat pump in a suitable place outdoors so there is no risk that the refrigerant, in the event of leakage, can flow in through ventilation openings, doors or similar openings, or in any way that constitutes a danger to people or property.
- All wall ducts must be gas-tight. This also includes wall ducts that are sited in the safety area below ground level.
- If the heat pump is placed in a site where any refrigerant leakage could accumulate, for example, below ground level (in a dip or recess), the installation must fulfil the same requirements as those that apply for gas detection and ventilation of machine rooms. Requirements with regards to sources of ignition must be applied where applicable.
- The heat pump has a factory-fitted condensate tray, from which condensation water is conducted via the condensation water pipe to a caisson, storm drain, downpipe or other drainage equipment. You should therefore consider the position of the product.
- Allow a space of at least 2 metres between the heat pump and any bushes etc. and leave an access and service area of at least 1 metre on each side of the heat pump.
- Place the heat pump so that noise from the compressor and fan does not disturb the surroundings.
- Do not place the heat pump right next to a bedroom window, patio or property boundary. Consider the distance to the nearest neighbour.
- The leg frame must stand stably on a permanent foundation, preferably a concrete foundation.
- Due to the design of the leg frame and the weight of the pump, it is not necessary to anchor the unit to the ground or the wall.

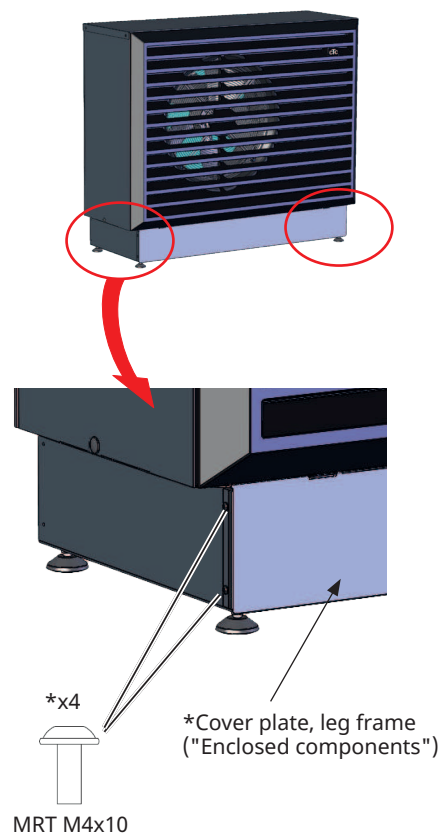

- It is inappropriate to build protection around the heat pump, as the air must be able to flow in through the evaporator as freely as possible, and it must not be possible for used air to be sucked back through the inlet on the back. The same applies to placing the product in an outbuilding or carport. This can cause abnormal ice formation on the evaporator.
- If the product is positioned so that it is exposed to extra harsh weather conditions, then a screen may be recommended.

11.3 Preparation and drainage

The heat pump should be positioned so that the property cannot be damaged and the condensation water can be dealt with easily.

If the condensation water is to be drained to the property's wastewater system, this must occur via a water trap; see the chapter "Condensation water".

If condensation water is allowed to run down into the ground, the foundation must be made of concrete blocks, concrete foundation or similar that rests on crushed stones or shingle. The condensation water pipe's outlet must be positioned at a frost-free depth.

- Create a "caisson" under the heat pump. Remember that there may be up to 70 litres of condensation water a day under some conditions.
- Excavate to a depth of 70-100 cm and place moisture-proof matting into the ground and angle this outwards from the property.
- Fill the hole halfway up with crushed stones and lay a concrete block or similar.
- Measure out the correct measurement between the concrete blocks so that the legs of the heat pump will fit in; see the chapter "Technical Data/Dimensional Drawing".
- Use a spirit level to ensure that the blocks are level.
- Place crushed stones in and around the blocks to achieve optimal drainage.

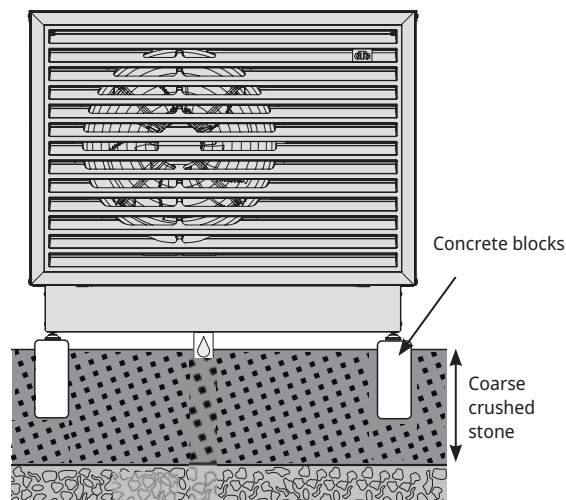

11.4 Condensation water

- The condensate tray is built into the heat pump and is used to divert most of the condensation water.
- The condensation water can either be allowed to run down into a "caisson" in the ground (see the chapter "Preparation and drainage") or be led off to the property's drainage system (e.g. downpipe drain) via a drainage pipe connected to the pre-installed condensate water drain via a water trap.
- A heating cable (available as an accessory) should be installed in the condensate water drain from the condensate tray and down to a drain at frost-free depth to prevent freezing. The heating cable is connected to the electrical cabinet of the heat pump (the installation must be carried out by a qualified electrician in accordance with applicable regulations).

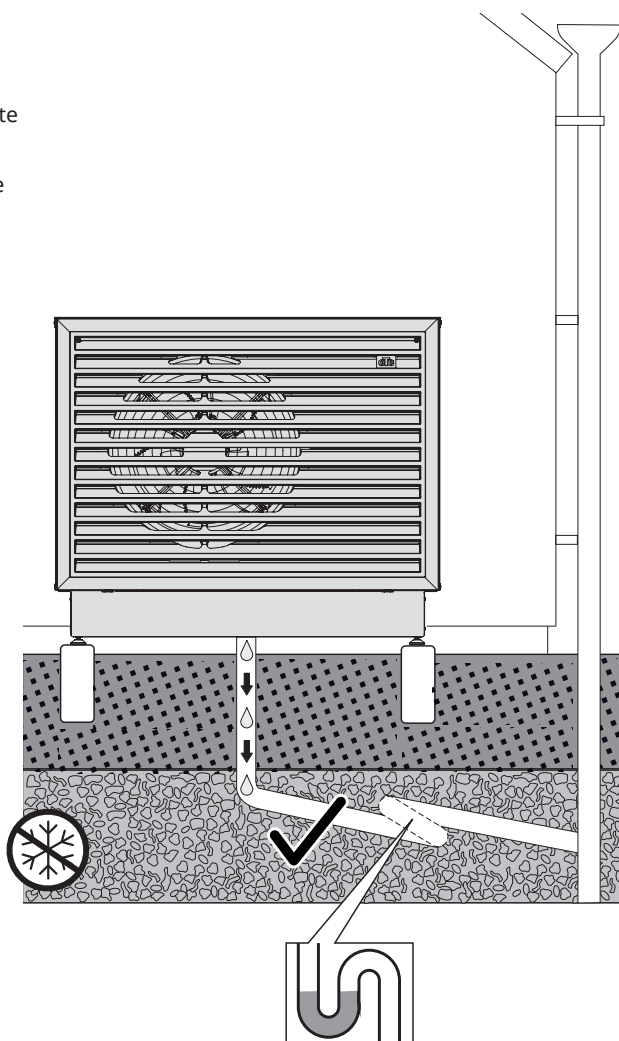

WARNING!

If refrigerant collects in the drainage system (e.g. due to a leak in the cooling circuit), there is a risk of explosion.
 ► Only connect the condensation water drainage to the drainage system via a water trap to prevent air from circulating in the condensation water pipe.

12. Pipe installation

The installation must be carried out in accordance with the applicable standards. The indoor module must be connected to a closed expansion tank. If necessary, the heating circuit(s)/radiator system(s) must be flushed clean before connecting.

12.1 Pipe connection

- We recommend that the heat pump be connected with a pipeline of at least Ø28 mm copper pipe, but pressure differential calculations must be carried out to determine the pipe diameter.
- The piping between the heat pump and the indoor unit should be done without any high points. If this cannot be done, provide this high point with an automatic bleeder.
- Check the safety valves' stated opening pressure. The safety valve in the heat pump must open before the safety valve in the indoor unit (the control product). The safety valve in the outdoor unit must therefore have a lower opening pressure than the safety valve in the indoor unit.

Note!

Safety valve(s) indoors must have an opening pressure of at least 2.5 bar, as the inbuilt safety valve in the outdoor unit has an opening pressure of 2 bar (0.5 bar lower opening pressure). Replace the valves indoors if this is not the case.

- Fit the packaged filter ball valve to the return flow from the indoor unit. To clean the filter ball valve; see the chapter "Operation and maintenance".
- The connection to the heat pump should be made with a wire-reinforced diffusion-tight hose for DHW, min. 1" diameter (available as an accessory). A minimum 1000 mm flexible hose is required to prevent noise transmission into the property and to absorb any movements from the heat pump.
- Pipes installed outside should be insulated* with at least 13 mm thick, water-resistant pipe insulation. Ensure that the insulation is sealed tightly and comprehensively and that joints are thoroughly taped or glued.
- Indoor pipes should be insulated* as far as the indoor unit with at least 9 mm thick insulation. This is to allow the heat pump to deliver the highest possible temperature to the indoor unit or tank without any losses.



The indoor module must be connected to a closed expansion tank.



Minimum water volume in the heating circuit (>25 °C) for reliable defrosting functionality:

EcoAir 708M/712M: 80 l



Safety valve(s) indoors must have an opening pressure of at least 2.5 bar, as the inbuilt safety valve in the outdoor unit has an opening pressure of 2 bar (0.5 bar lower opening pressure). Replace the valves indoors if this is not the case.

12.2 Example of connection of the heat pump to CTC EcoZenith (L) indoor module

The CTC EcoZenith i360 (low version) has pipes at the back right edge for connecting the heat pump. The heat pump's lower connection is connected to the right connection when viewed from the front of the indoor unit, which means that the return flow water is pumped out to the heat pump. The heat pump's upper connection is therefore connected to the left connection.

The circulation pump and reversing valve are factory installed in the indoor unit.

See the indoor module's Installation and Maintenance Manual for information on connecting the heat pump.

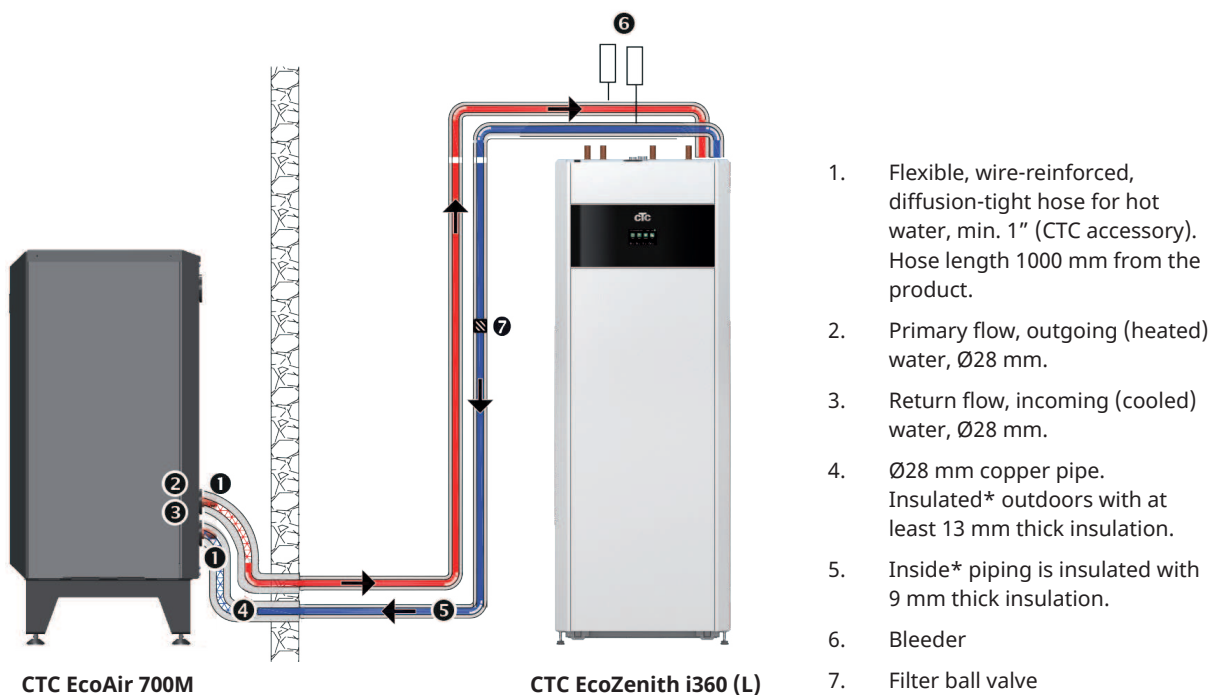

** Observe national and/or local regulations when dimensioning the thickness of pipe insulation.*

12.3 Pressure drop chart

The chart below shows the total water pressure drop for the heat pump.

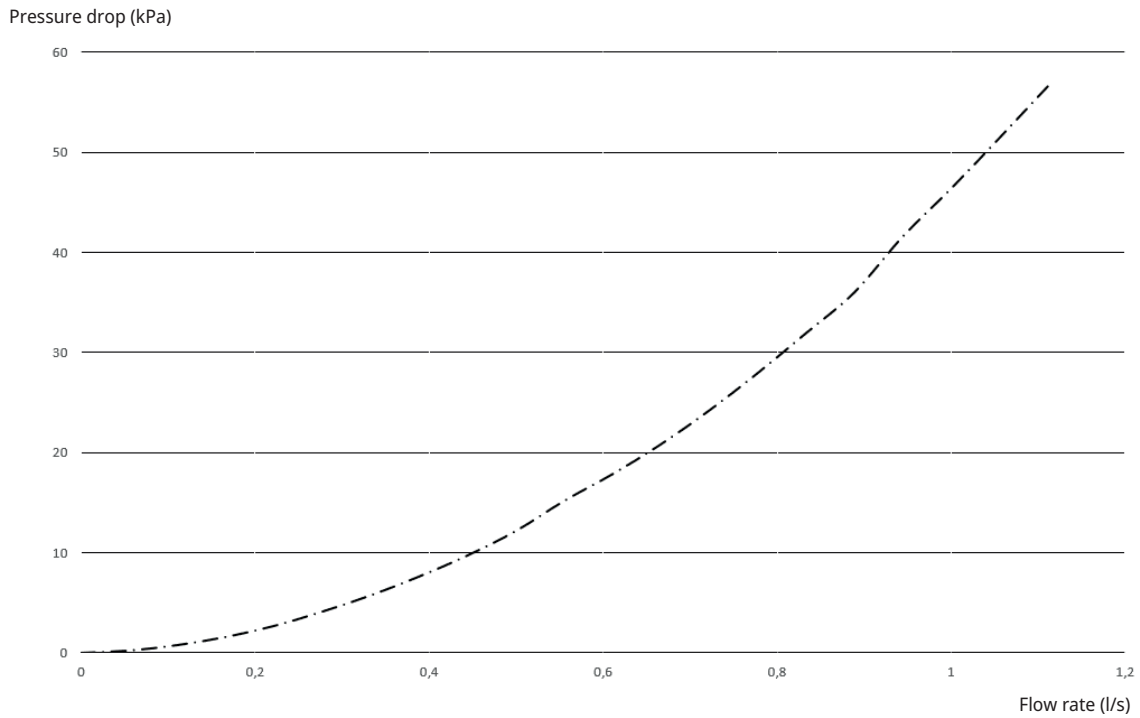

Heat pump	Kvs value
CTC EcoAir 708M	5.35
CTC EcoAir 712M	5.35

13. Electrical installation



WARNING!

- The operating power switch is a potential source of ignition that should be placed outside the safety area; see the chapter "Safety area".
- Accessories* that are not A3-classed must not be connected in the electrical cabinet due to the risk of sparking.
- If the power cable has been damaged, this must be replaced by the manufacturer or other authorised staff to avoid danger.
- The product's electrical systems may only be installed and serviced by a qualified electrician. All wiring must be installed according to applicable provisions.
- The power must be cut off with an operating power switch before the cabinet is opened or other live parts are made accessible.
- Check that the product is disconnected and wait approx. 5 minutes before performing measures when the product may have a remaining charge.
- The installation should be preceded by an omnipolar safety switch under over-voltage category III, which ensures disconnection from all electric power sources.
- The product must be connected to a protective earth.
- If there already is a residual current device, the heat pump must also be fitted with its own ground residual current device with on/off delay.
- The 2 m long power supply cable is pre-connected to the product.
- When connecting accessories* in the electrical cabinet, lead through may occur in any of the three holes in the base plate, which are accessible from the back of the heat pump.

Note!

Remove the cover and side plates and use the intended indentations in the upper insulation of the cover when inserting cables inside the product.



The product's electrical systems may only be installed and serviced by a qualified electrician. All wiring must be installed according to applicable provisions.

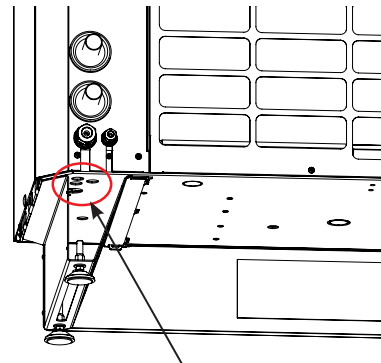

Lead-through hole (x3)

**Only accessories that have been approved by CTC may be installed. Wiring diagram "HP PCB (A5)" shows how relevant accessories must be connected.*

13.1 Communication connection

13.1.1 Series connection of heat pumps

Upon delivery from the factory, the terminating resistor is connected in the electrical cabinet's upper terminal block (-X3) between terminal blocks A and B, while the shielding in the communication cable is connected to earth through the jumper that sits between the SC and PE terminal blocks.

In the series connection of heat pumps, the terminating resistor must only be connected to the last heat pump in the series and removed from the other heat pumps in the series.

For all heat pumps apart from the last in the series connection, the jumper that sits between terminal blocks SC and PE must also be removed and the shielding (terminal block SC) must be transferred to the next heat pump.

When connecting several heat pumps, the heat pumps must be given the correct name in the display. All heat pumps are factory-set addressed as HP1. The chapter "Defining multiple heat pumps" shows how heat pumps are addressed (HP1-) from the control product onwards.

! The terminating resistor must only be connected to the last heat pump in the series connection.

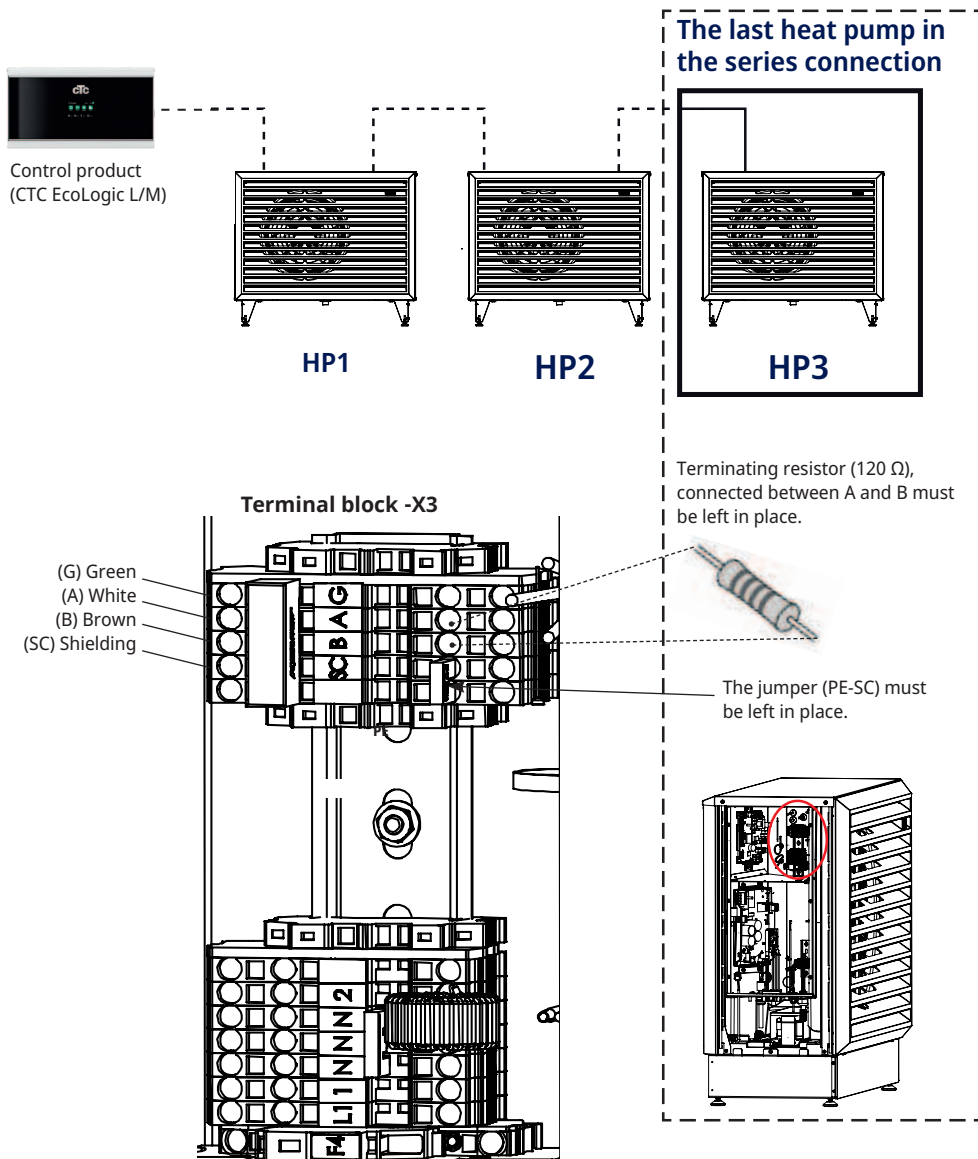

13.1.2 Defining multiple heat pumps

Define the heat pumps in the control product's display under: "Advanced/Define system/Heat pump".

Set the heat pumps included in the system to the "On" position.

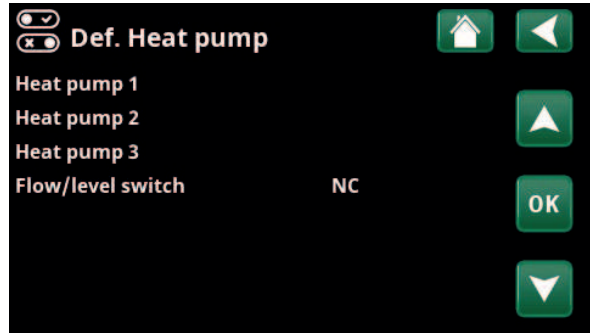

Example of a system with three heat pumps. Menu "Advanced/Define system/Heat pump"

13.1.3 Numbering CTC EcoAir 700M

All heat pumps are supplied as HP1. The example below shows how heat pumps are numbered in a series connection.

1. BMS connection (RJ12)
2. Network connection, Ethernet (RJ45)
3. Display unit power supply/Internal communication (RJ45)

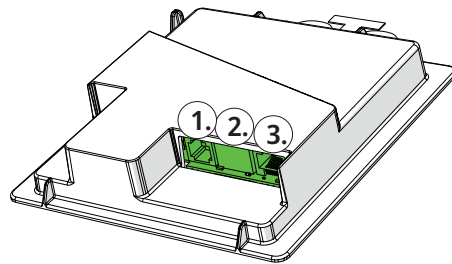

1. System disconnected from power.

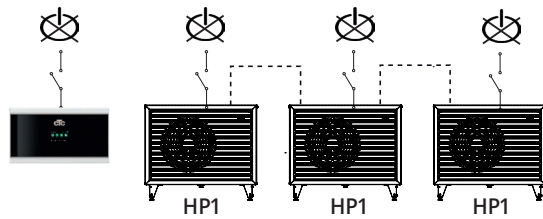

2. Power up the control (CTC EcoLogic L/M, CTC EcoPart i600M or EcoZenith i555 Pro) as well as CTC EcoAir 700M, which will be numbered as Heat Pump 2 (HP2).

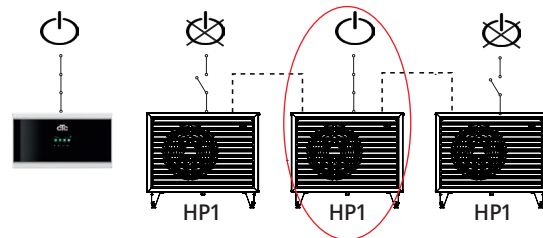

3. Wait for about 2 minutes.

4. Go to "Advanced/Service/Set Address".

Select "Current address", press OK and press the down arrow until the current heat pump appears (HP1). Press OK.

Select "New address", press OK and use the arrow to scroll up and down until the relevant address of the heat pump is shown (HP2). Press OK.

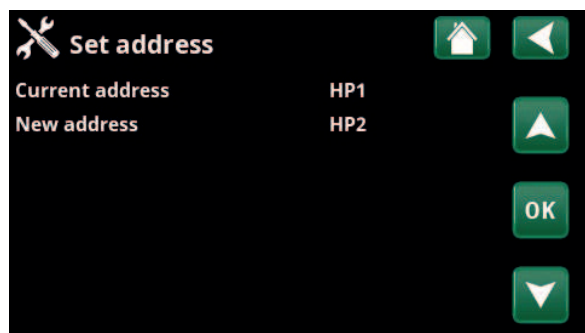

5. The heat pump is now numbered (HP2).

When you press OK, (HP1 and HP2)* disappears and the row "Current address/New address" will go dark.

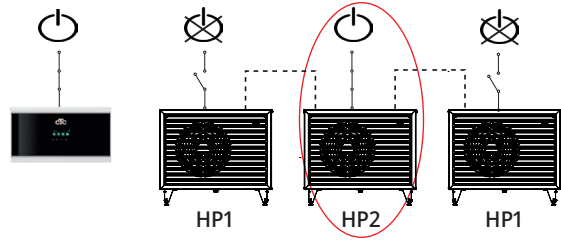
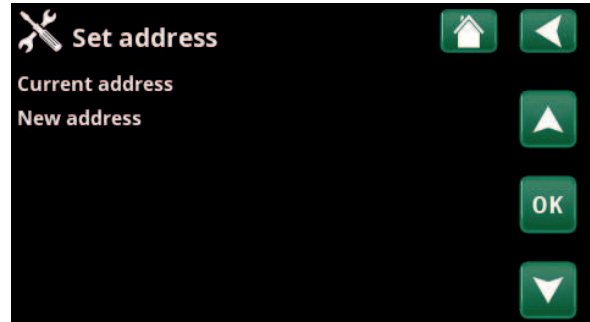

6. Number the other heat pumps:

Power up the next heat pump, which will be numbered heat pump 3 (HP3).

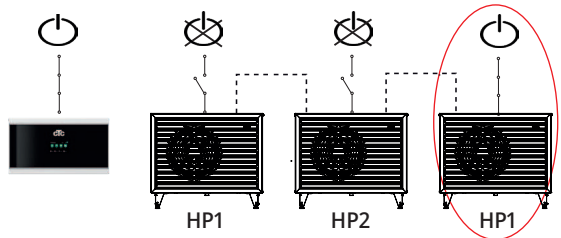

7. Wait for about 2 minutes.

8. Go to "Advanced/Service/Set Address".

Select "Current address", press OK and press the down arrow until the current heat pump appears (HP1). Press OK.

Select "New address", press OK and use the arrow to scroll up and down until the relevant address of the heat pump is shown (HP3). Press OK.

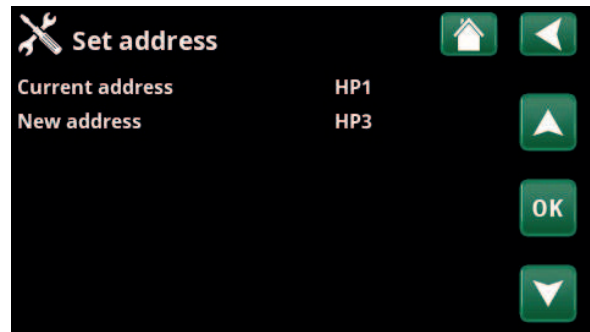

9. The heat pump is now numbered (HP3).

When you press OK, (HP1 and HP3)* disappears and the row "Current address/New address" will go dark.

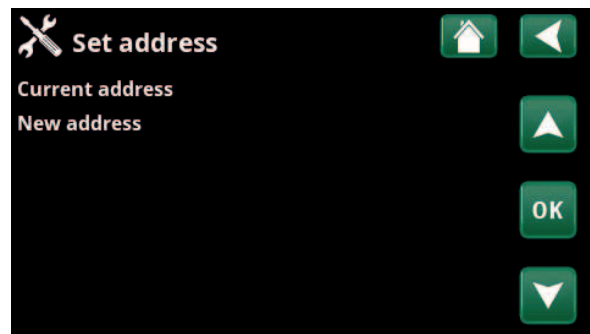

10. Redo the process according to the number of heat pumps to be numbered.

**In this example, we have assumed that the heat pump is called HP1, as it is from the factory. If the heat pump has already been renumbered, then select this number instead.*

When all heat pumps are numbered and powered up, they should be displayed when you press the heat pump symbol in the menu "Operation data". If any heat pump does not appear in the menu (communication with the heat pump fails), this may be because it has not been numbered as described above.

If you do not know the name of the heat pump, you can reset the numbering by using the "Set address" menu (refer to points 9 and 10 above) to indicate all possible names of the heat pump, i.e. you select and confirm HP1 and then HP2 up to HP10 to ensure that the correct name is given.

Test that the respective heat pump starts via the "Advanced/Service/Function test/Heat pump" menu.

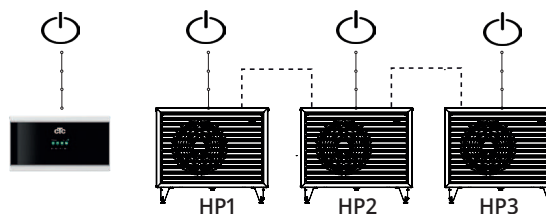

Troubleshooting addressing

Error when setting address

- The heat pump could not be found and numbered.
- The heat pump has not been named as it was presumed to be named.
- No communication with the heat pump.

Check that the heat pump is powered up.

If the address setting fails, the latest heat pump addresses remain. In this example HP1 and HP2.

- Make sure the heat pump is powered up.
- Try again with a new current address.

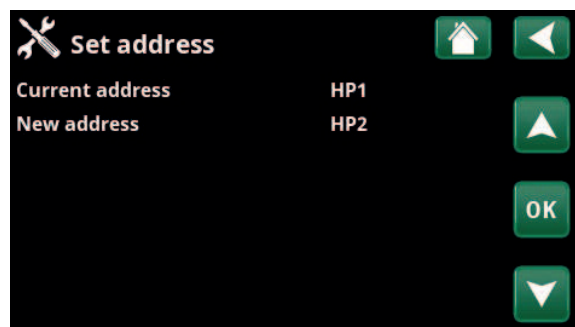
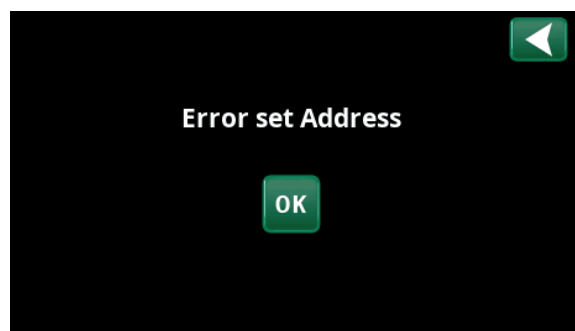

13.1.4 Connecting one heat pump

When connecting CTC EcoAir 700M to the control products, connect the communication cable (LiYCY (TP)) directly to the respective product.

13.1.5 Alarm output

The heat pump is provided with a potential-free alarm output at the HP PCB (Extern out 1/C7), which is activated if any alarm is active in the heat pump. This output may be connected to a maximum load of 1 A, 250 V AC. Cable approved for 230 V AC must be used for connecting this output, irrespective of the load that is connected. For connection, see the heat pump's Wiring diagram.

13.2 Connection table for electrical components

Component	Designation	Option	Page of wiring diagram	Connection
A5	HP PCB			
A7	I/O Expansion card			
A10	Frequency converter (driver)			
B1	Primary flow sensor (Type 2 NTC)		/4	X1A-(E)5 X1A-(F)6
B7	Return flow sensor (Type 2 NTC)		/4	X1B-(A)1 X1B-(B)2
B15	Outdoor sensor (Type 1 NTC)		/4	X2-(A)1 X2-(B)2
B16	Defrosting sensor (Type 1 NTC)		/4	X1A-(C)3 X1A-(D)4
B20	Outgoing air sensor		/4	X1A-(A)1 X1A-(B)2
B21	Hot gas sensor (Type 6 NTC)		/4	X2-(E)5 X2-(F)6
B22	Suction gas sensor (Type 1 NTC)		/4	X3-(A)1 X3-(B)2
B29	Suction gas sensor 2 (Type 1 NTC)		/4	X2-(C)3 X2-(D)4
B40	Temperature sensor, AC coil (Type 4 NTC)		/2	X24B
B48	Flow sensor		/4	X27B
B62	Temperature sensor, compressor (Type 6 NTC)		/4	X3-(C)3 X3-(D)4
B100	High pressure sensor		/4	X14
B101	Low pressure sensor		/4	X13
B106	Thermal switch		/1	
B111	Temperature sensor, liquid line (Type 1 NTC)		/4	X3-(E)5 X3-(F)6
C1	Suppression capacitor		/3	X3:PE GND
E11	Heating coil for condensate tray		/2	X25B
E12	Heating cable for condensation water drain	X	/2	N PE F1:1
F0	Automatic fuse		/1	L1 X2:L1
F1	Coupling set, tube fuse etc.	X	/2	A5/NO4
F4	Tube fuse		/1	F0:1 X2:1
F20	High pressure switch		/1	X22B
G11	Charge pump	X	/4	X4-(D)4 X4-(E)5
L1/L2/L3	AC coils		/1	X37
L4	Line choke		/1	X2/N X2:2
M10	Fan		/4	X26B X11
M1	Compressor		/1	A10/U, V, W, PE
Y10	Expansion valve		/2	A5/EV1
Y11	Four-way valve		/2	A5/NO2

13.3.2 HP PCB /2

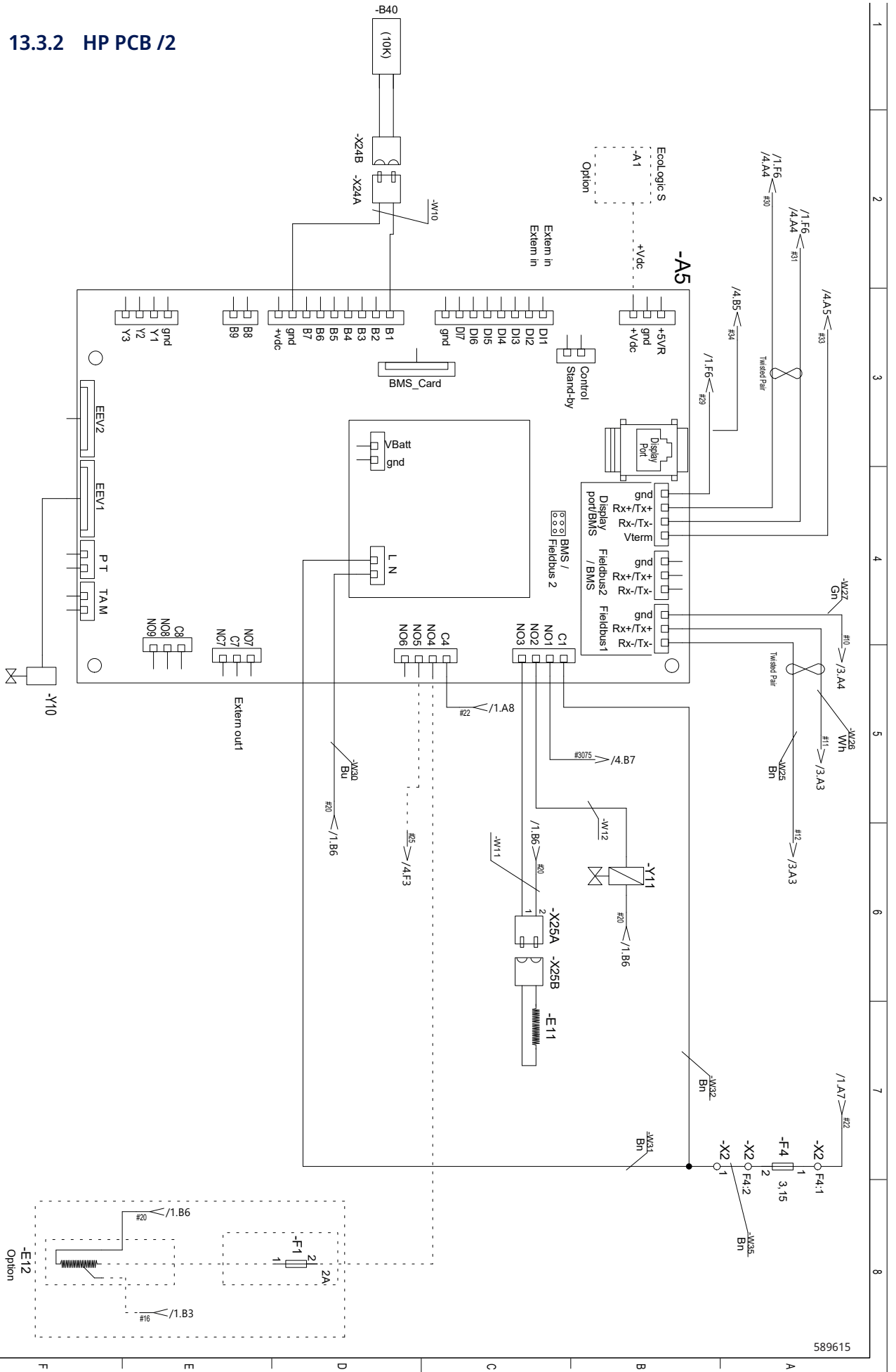

589615

13.3.3 Communication /3

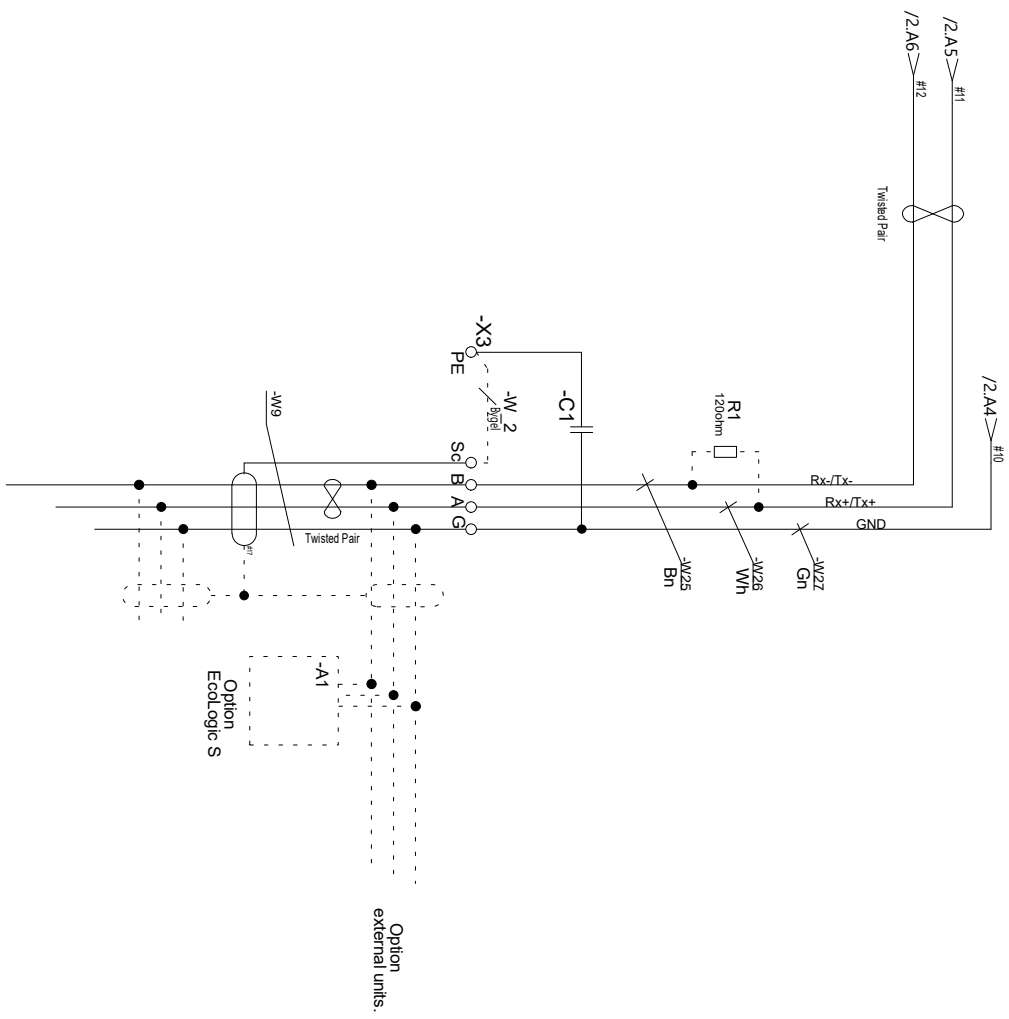

	3	4	5	6	7	8
--	---	---	---	---	---	---

589615

--	--	--	--	--	--	--

13.3.4 I/O Expansion card /4

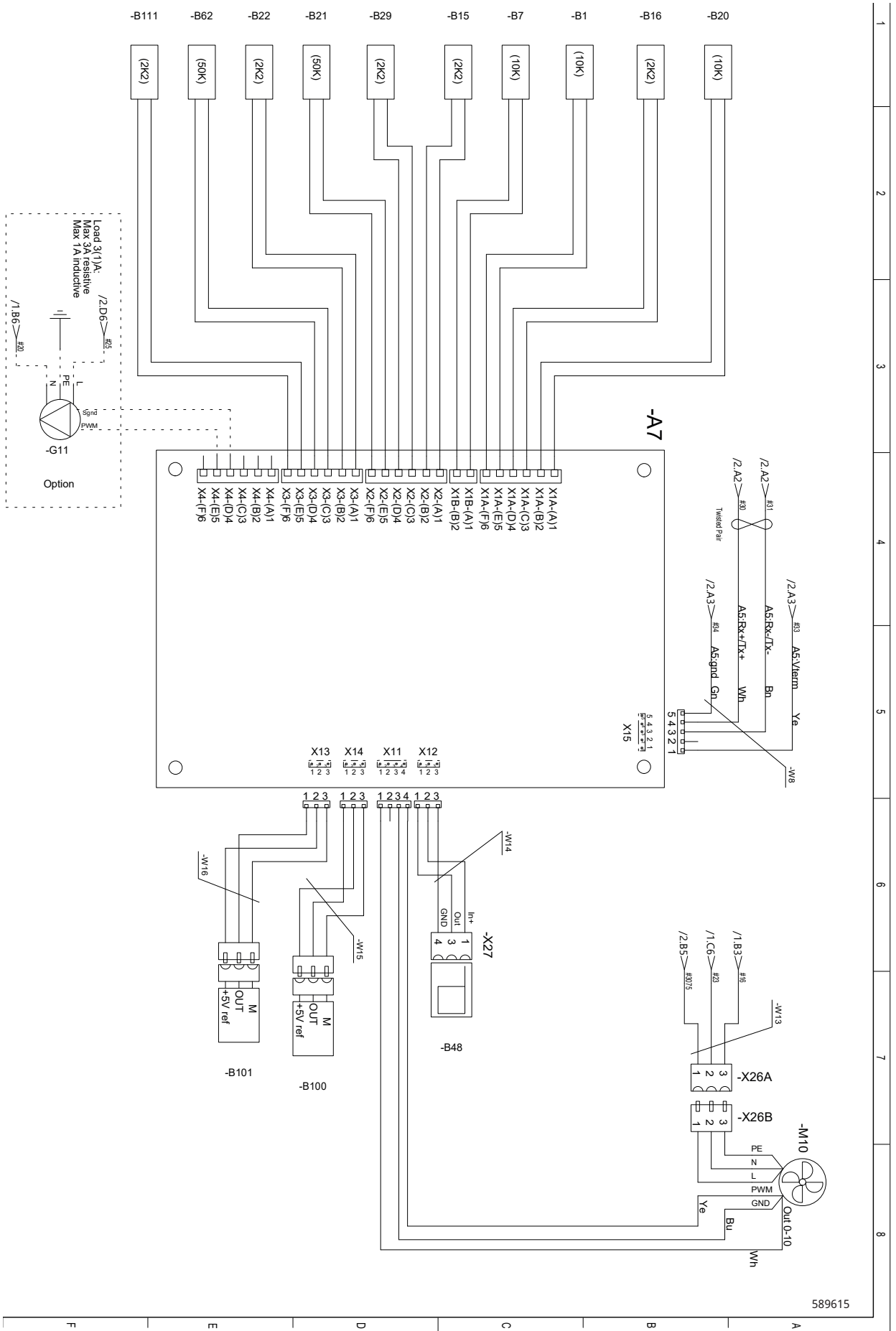

589615

13.4 Wiring diagram 230V 1N~

13.4.1 Frequency converter (driver) /1

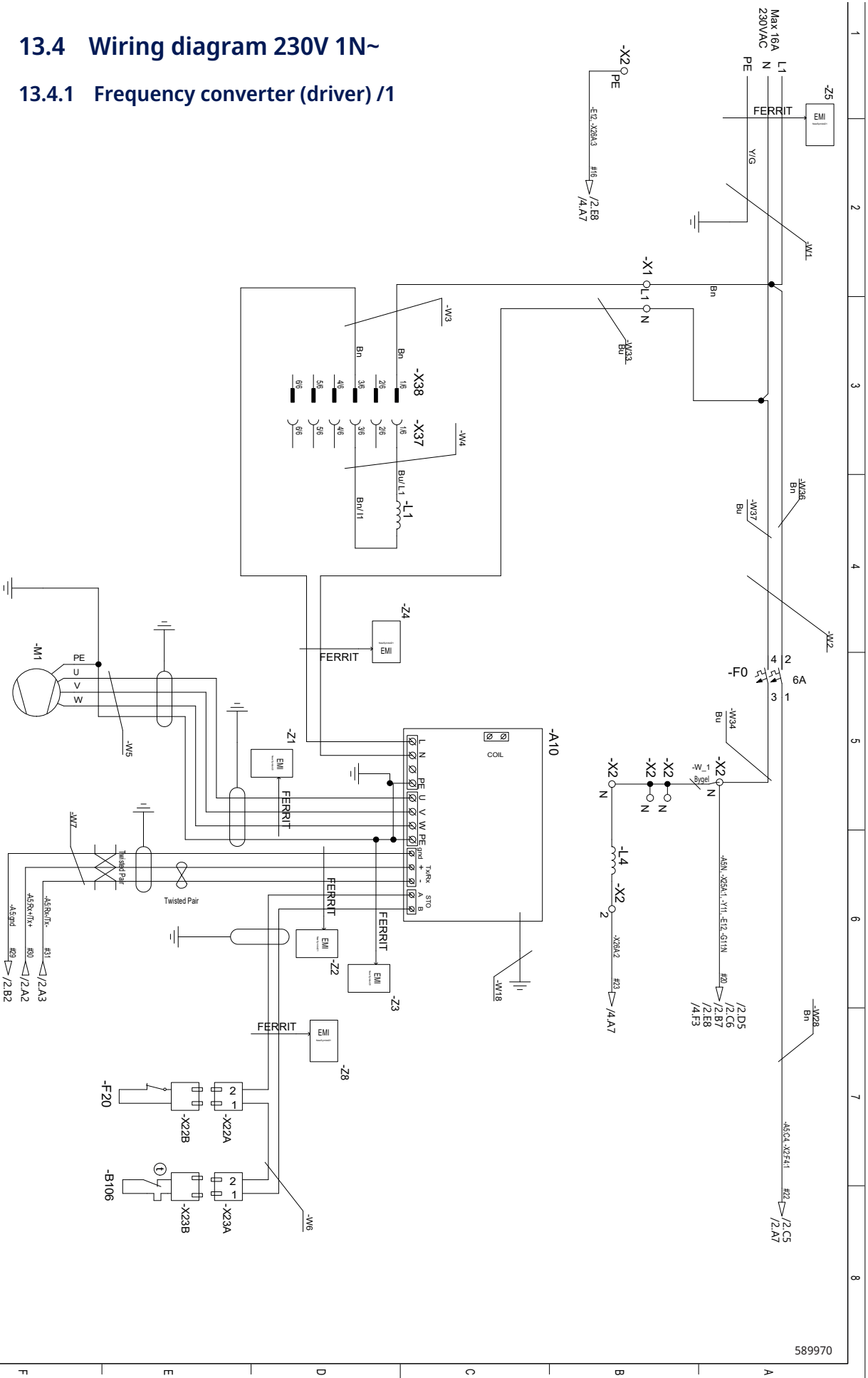

589970

13.4.3 Communication /3

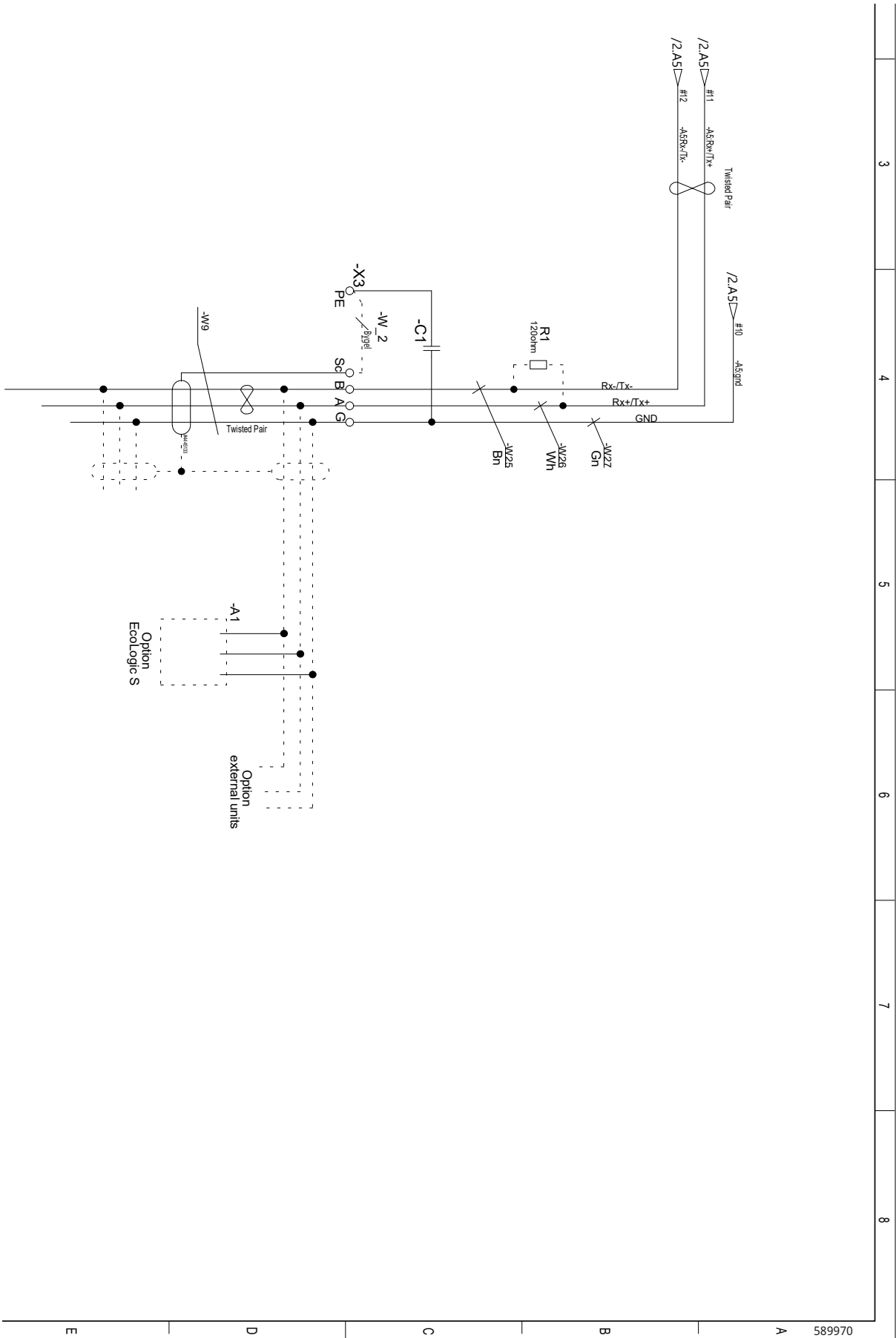

13.4.4 I/O Expansion card /4

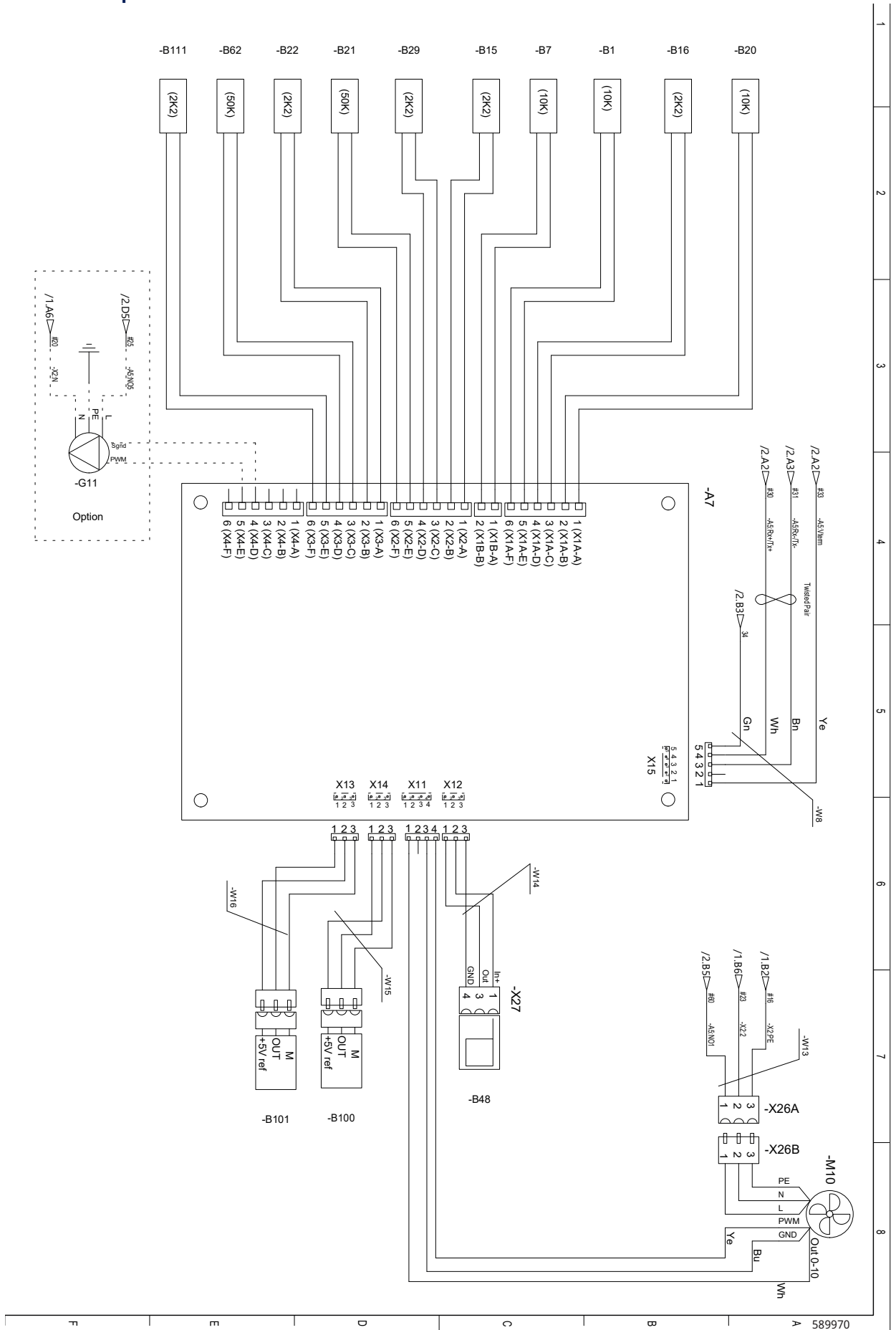

14. First start

1. Check that all parts of the heating circuit are full of water and have been bled.
2. Check that all connections are tight.
3. Check that sensors and pump(s) are connected to the power source.
4. Energise the heat pump by turning on the operating power switch.
5. Switch on the power of the control product with the operating power switch and step through the start-up sequence in the Installation guide* on the display of the control product.
6. The start of the heat pump is delayed if the compressor temperature is too low. Compressor heating is active until the calculated start value is reached.
See the compressor heating status* in the menu "Operation data".
7. Once the system has heated up, check that all connections are tight, bleed again the different parts of the system, check that heat is coming out into the system and warm water is coming out at the tap locations.



The heat pump will not start without air flow through the evaporator or water flow through the condenser.



Defective components must be replaced with original parts from CTC.

15. Operation and maintenance

When the installer has installed your new products, you should check along with the installer that the system is in perfect operating condition. Let the installer show you where the power switches, controls and fuses are so that you know how the system works and how it should be maintained. Bleed the radiators (depending on type of system) after around three days of operation and top up with water if required.

Defrost

The CTC EcoAir 700M is fitted with hot gas defrosting. The heat pump continuously checks whether defrosting is required. If this is the case, defrosting is started, the fan stops, the four-way valve switches direction and the hot gas flows instead to the evaporator. A hissing sound is heard as the water drains from the evaporator. There may be large amounts of water.

Noise may also occur if the charge pump needs to increase the speed during defrosting to meet the flow requirement.

The flow requirement at defrost is 10 l/min. If the flow rate falls below this value, an alarm is generated.

When the product has defrosted, the fan starts and the hot gas flows into the condenser instead, and the heat pump returns to normal operation.

The front, ice formation

Ice formation on the front must not be broken loose but the ice removed instead with lukewarm water.

Cleaning

The heat pump must be cleaned on the outside with water and mild detergent.

Note!

The product must not be cleaned with a high pressure jet.

Modulating compressor

The heat pump power is adapted using modulating operation according to the actual energy requirement. The compressor runs constantly with the correct power and thereby minimises the number of start and stop periods. The modulating power regulation provides optimal efficiency.

Start-up delay

The heat pump starts with a delay if the compressor temperature at start-up is below a calculated start value. Compressor heating is active until the start value is reached.

Delay when switching to hot water mode

The heat pump will switch from heating mode (HC mode) to domestic hot water mode (DHW mode) with some delay in case the compressor needs to heat up before the switch. The heat pump will remain in HC mode while the compressor heating is in progress.

Since compressor heating may be needed when switching to DHW mode, it is advisable to extend the maximum time for hot water to 40 minutes (menu "Max time DHW (min)"*) and shorten the maximum time for heating to 20 minutes (menu "Max time heating (min)"*).

Switching to/from cooling mode

The compressor always stops when switching to or from cooling mode.

Delay of return flow temperature measurement at start-up

The control system decides if compressor heating is needed at start-up by measuring the temperature of the heat pump return flow.

Set a delay time before the control system is allowed to measure the return flow temperature, see menu "HC<->DHW time (sec.)" or "Delay primary flow temp (sec.)"* , depending on the control product.

The fan

The fan starts before the compressor starts and runs until the compressor stops. The fan also starts if the driver becomes too hot during compressor heating.

The fan stops during defrosting and restarts when defrosting is finished. The fan is speed-controlled and follows the power requirements.

Charge pump

The charge pump transports the heat from the heat pump to the indoor unit/boiler. If the outdoor temperature is below +2 °C, the pump runs constantly to eliminate any risk of freezing.

In cooling mode, the speed of the charge pump will increase if the product approaches the alarm limit "Risk of freezing".

The speed for the charge pump is set in the "Advanced/Settings/Heat pump"* menu.

Bleeding

The heat pump is automatically bled via the gas separator.

● The heat pump starts with a delay if the compressor temperature at start-up is below a calculated start value.

● Since compressor heating may be needed when switching to DHW mode, it is advisable to extend the maximum time for hot water to 40 minutes (menu "Max time DHW (min)"*) and shorten the maximum time for heating to 20 minutes (menu "Max time heating (min)"*).

● Set a delay time before the control system is allowed to measure the return flow temperature.

**For more information, see the Installation and Maintenance Manual of the control product.*

Maintenance

A large amount of air passes through the evaporator. Leaves and other debris can get stuck and restrict the air flow. The evaporator should be checked and cleared of particles that block the air flow at least once a year. The evaporator and outer covering should be cleaned with a damp cloth or soft brush.

Periodic maintenance

After three weeks of operation and every three months of the first year, thereafter once a year:

- Check that the installation is free of leakage.
- Check that the product and system are free of air; bleed if needed.
- Check that the evaporator is clean.
- Check the safety valve by turning the knob and checking that water comes out in the overflow pipe. The safety valve is positioned behind a rubber protector on the back of the heat pump above the primary flow outlet.
- Clean the filter ball valve located on the heat pump's return flow in the following way:
 - Turn off the heat pump with the operating power switch.
 - Close the filter ball valve (switch to the OFF position) and unscrew the cover underneath.
 - Use lock ring pliers to remove the lock ring securing the filter.
 - Remove the filter and rinse clean.
 - Refit the filter and lock ring.
 - Reattach the cover carefully and make sure to not pinch the O-ring gasket.

Operation stop

The heat pump is shut down using the operating power switch. If there is a risk of the water freezing, ensure that there is circulation or drain out all the water from the heat pump.

The condensate tray

The condensate tray collects water formed on the evaporator during operation and defrosting. The condensate tray is equipped with an electric heating coil, which keeps the tray free of ice when it is freezing outside.

It is possible to make settings for the heating coil's heating time in relation to the outdoor temperature, see menu "Advanced/Settings/Heat pump"*.

The condensate tray sits at the bottom of the back of the heat pump. By lifting the cover plate, you can clean and inspect the tray.

Note!

There is a risk of damaging/ripping the evaporator when cleaning the condensate tray.

You can purchase a heat cable as an accessory, which is installed in the condensation water drain from the condensate tray and down to the drain at a frost-free depth.

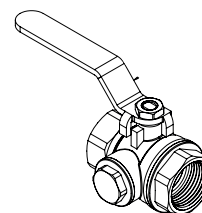
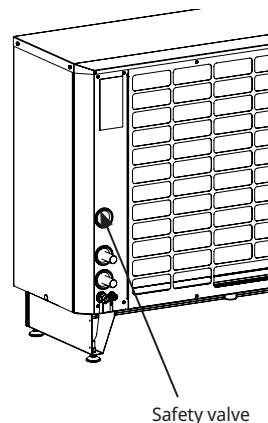

Filter ball valve in open position "ON".



Condensate tray and condensation water drain.

**For more information, see the Installation and Maintenance Manual of the control product.*

16. Troubleshooting

The CTC EcoAir 700M is designed to provide reliable operation and high levels of comfort, and to have a long service life. Various tips are given below to provide help and guidance in the event of an operational malfunction.

If a fault occurs, you should always contact the installer who installed your unit. Always provide the product's serial number.

Alarms

Any alarms and information texts from the CTC EcoAir 700M are displayed in the display* of the control product.

Circulation and defrosting

If the circulation between the indoor unit and the heat pump is reduced or stops, the high pressure switch is triggered.

Possible reasons for this:

- Circulating pump defective or too small
- Air in the pipe.
- Condenser clogged.
- Other intermediate obstructions to the water flow.

During defrosting, the fan stops but the compressor operates, and the melted snow and ice flows into the condensate tray under the heat pump. When defrosting stops, the fan starts again and a vapour cloud, which consists of damp air that condenses in the cold outdoor air, is initially created. This is perfectly normal and stops after a few seconds. If the pump heats poorly, check that no unusual ice formation has occurred.

Possible reasons for this:

- Defective defrosting automation.
- Lack of refrigerant (leakage).
- Extreme weather conditions.

Unusually low system pressure, leak detection

If the system pressure of the heating circuit drops and approaches no pressure, find the reason for this. However, it is normal for the system pressure to vary to some extent depending on the system temperature.

Do not forget to also check the heat pump safety valve. Its outlet pipe is located under the bottom of the heat pump.

Note!

A leaking safety valve can cause a frozen outlet pipe at freezing outdoor temperatures.

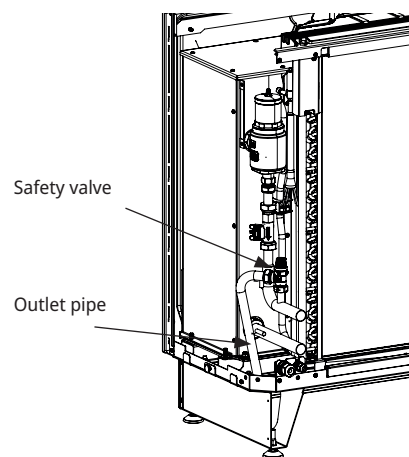

**For more information, see the Installation and Maintenance Manual of the control product.*



012



CTC AB Box 309 SE-341 26 Ljungby
info@ctc.se +46 372 88 000
www.ctc.se